



WARNING: Installation, disassembly, repair and maintenance **MUST** be performed only by qualified personnel. All

gas **MUST** be evacuated from the system before starting repairs. Installation, usage and maintenance of this product must be in compliance with all RegO® instructions as well as requirements and provisions of NFPA #54, NFPA #58, DOT, ANSI, all applicable federal, state, provincial and local standards, codes, regulations and laws.

Inspection and maintenance on a periodic basis is essential. Be sure all instructions are read and understood before installation, operation and maintenance. These instructions must be passed along to the end user of the product.

RegO Rail Tank Car equipment is AAR approved. If repaired, the continued validity of the AAR approval is contingent upon proper inspection to determine what needs to be repaired; proper repair using RegO OEM parts and procedures, proper testing for leakage and performance following repairs and installation.

ECI EXPRESSLY DISCLAIMS ANY AND ALL LIABILITY – UNDER ANY THEORY, WHETHER CONTRACT, WARRANTY, TORT OR OTHERWISE – RELATING IN ANY MANNER TO ANY RAIL TANK CAR EQUIPMENT REPAIRED USING ANY PRODUCTS NOT MANUFACTURED BY ECI.

USE OF ANY PRODUCTS NOT MANUFACTURED BY ECI TO REPAIR ANY RAIL TANK CAR EQUIPMENT WILL INVALIDATE ANY AND ALL WARRANTIES OF THE RAIL TANK CAR EQUIPMENT, WHETHER EXPRESS OR IMPLIED.

CAUTION: Contact or inhalation of liquid propane, ammonia and their vapors can cause serious injury or death! NH₃ and LP-Gas must be released outdoors in air currents that will insure dispersion to prevent exposure to people and livestock. LP-Gas must be kept far enough from any open flame or other source of ignition to prevent fire or explosion! LP-Gas is heavier than air and may not disperse or evaporate rapidly if released in still air.

Disassembly and Rebuild Procedure

CAUTION: READ THROUGH ALL OF THESE INSTRUCTIONS, INCLUDING THE NOTICE AND WARNINGS ON THE BACK OF THIS SHEET, BEFORE BEGINNING ANY DISASSEMBLY OR REPAIR.

NOTE: Repairs must be performed in a clean area. Hands, clothing, tools and work area must be completely free of oil, grease and foreign matter to prevent contamination of component parts and valves.

DISASSEMBLY - SEE FIGURE 2

Excess Flow Assembly

1. Remove Body assembly from Collar, as not to damage the Poppet.
2. Remove external O-Ring from Body, and discard.
3. Remove Retaining Ring from top of Stem and discard.
4. Remove Washer and Hex Nut and set aside for reassembly.
5. Carefully slide the Poppet Assembly off the Stem while holding the Excess Flow Spring in place. Set the Poppet Assembly aside for disassembly.
6. Remove and discard the Excess Flow Spring.
7. Remove and retain the Lower Guide.
8. Remove and discard the Wire Retaining Ring from the Stem.
9. Remove and carefully retain Body from remaining assembled items. Do not damage threads or seat area.
10. Carefully remove and discard the Return Spring from the Stem.
11. Remove and retain the Stem Guide.
12. Carefully remove the O-Ring from the Stem without damaging the Stem, then discard the O-Ring.

CAUTION: Inspect Body** seat area and Stem** for signs of excessive wear and replace if necessary.

13. Take note of "L" or "V" on the top of the excess flow body. "L" signifies a liquid excess flow, while "V" signifies a vapor excess flow. Use this to determine which repair kit to use during reassembly. (See Figure 1).

Poppet & Seat Disassembly

14. Remove the six #8-32 Button Cap Screws holding the End Cap to the Poppet and discard
15. Remove the End Cap from the Poppet Assembly, and set aside for reassembly.



A3214L-50A, A3214L-50EA, A3214V-50A, A3214V-50EA Rebuild Kits for A3214 Series Internal Excess Flow Valves



16. Remove and discard the Seat Disc.

REASSEMBLY - SEE FIGURE 2

NOTE: Be sure all parts have been cleaned prior to reassembly. Where lubrication is required, use non-detergent grease.

Poppet & Seat Assembly

1. Install the Seat Disc onto the Poppet and place the End Cap on top.
2. Apply Loctite® TL222 thread locking compound to the threads of the six Screws and install into Poppet Assembly hand-tight.

CAUTION: Thread locking compound must not contact Seat Disc.

Excess Flow Assembly

3. Install the Spring Guide onto the Stem.
4. Install the Return Spring onto the Stem.
5. Carefully slide the Body onto Stem, aligning the Body to the Spring.
6. Install the Wire Retaining Ring to the Stem down in the Body.
7. Install the Lower Guide onto Stem until it rests on the Retaining Ring.
8. Apply LPG resistant Petro-Canada SVG102 or Mobil Centaur Moly 1 grease to the top two inches of the upper stem.
9. Install the Excess Flow Spring onto the Stem and let it rest on the Lower Guide.

NOTE: Take special care to choose the Excess Flow Spring that corresponds to the "L" or "V" on the body.

10. Lubricate O-Ring and carefully install onto the Stem.
11. Carefully install the Poppet Assembly onto the Stem, over the Excess Flow Spring as to not damage the stem O-ring.
12. Install Washer.
13. Apply Loctite 271® thread locking compound to Stem threads and install Hex Nut to the Stem and hand-tight.

CAUTION: Thread locking compound must not contact O-Ring.

14. Install the Retaining Ring to the end of the Stem.

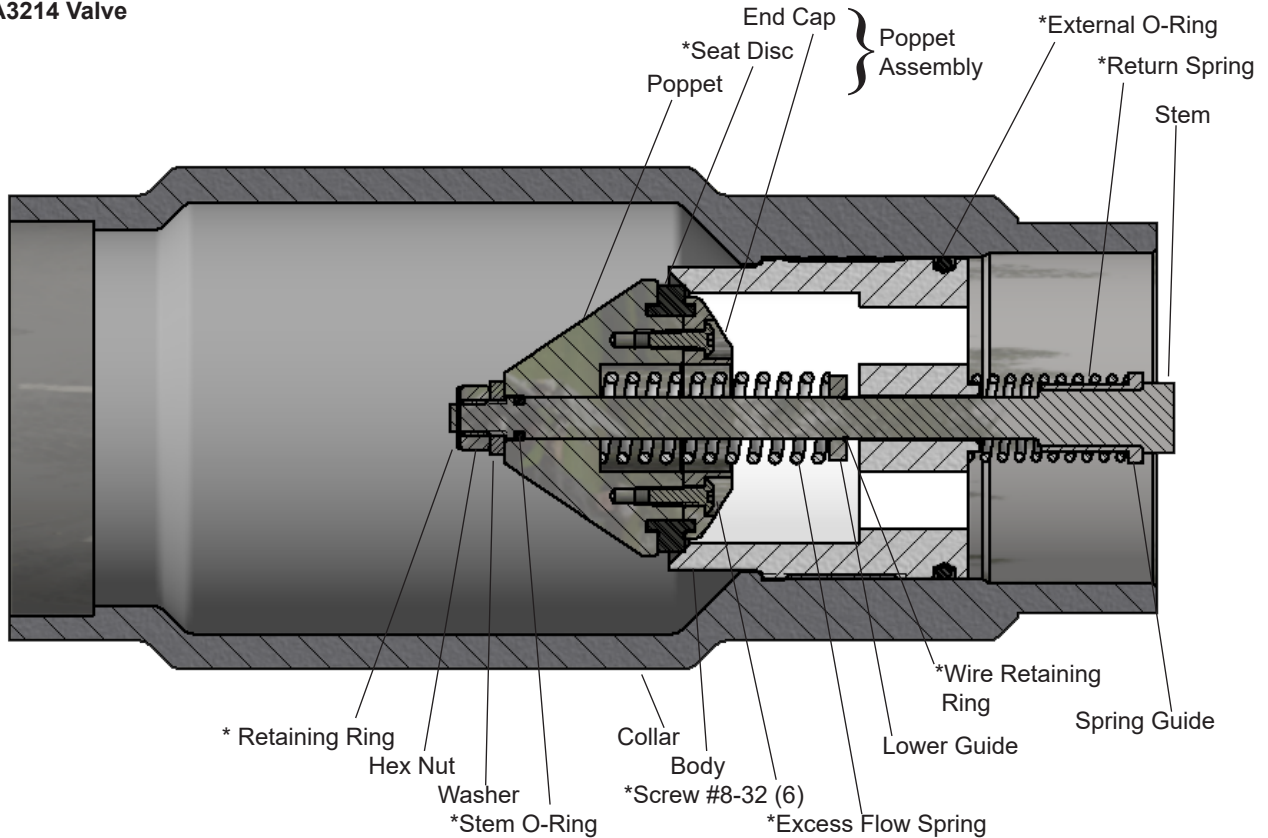

Figure 1 - Liquid or Vapor Stamp

"L" = Liquid
(Red Stripe on Spring)
"V" = Vapor
(White Stripe on Spring)

NOTE: Take special care to choose the Excess Flow Spring that corresponds to the "L" or "V" on the body.

Figure 2 - A3214 Valve



*Items included in kit recommended for most rebuild.

** Must be ordered separately from RegO.

15. Lubricate External O-Ring and carefully install onto the Body.
Test

Pressurize the inlet side of the valve (cone side) to 500 psig with compressed air, nitrogen, or other inert gas. On the outlet side of

the valve apply a suitable leak detection solution to the area where the seat disc meets up with the valve seat; if a leak is indicated the valve must be reassembled or replaced.

NOTICE

LP-Gas is extremely flammable and explosive. Failure to install parts exactly as described in the instructions could result in a product that will not perform satisfactorily. Even if parts are correctly installed, the product might fail to perform satisfactorily, if other parts are worn, corroded or dirty. Improper repair can cause leaks and malfunction, which could result in bodily injury and property damage. Any such use or installation of parts must ONLY be done by experienced and trained personnel using accepted governmental and industrial safety procedures.

Most RegO® products are listed with Underwriters Laboratories as manufactured. If repaired, the continued validity of the UL listing is contingent upon proper inspection to determine what needs repairing, proper repair using RegO® parts and procedures, and proper testing for leakage and performance following repairs and installation.

RegO® assumes no responsibility or liability for performance of products repaired in the field. It must be clearly understood that the person or organization repairing the product assumes total responsibility for performance of the product.

LIMITED 10 YEAR WARRANTY

RegO® warrants to the original purchasers the products and repair kits manufactured by it to be free from defects in materials and workmanship under normal use and service for a period of 10 years from the date of manufacture. If within thirty days after buyer's discovery of what buyer believes is a defect, buyer notifies in writing and ships (at buyer's expense) the product to RegO® at 100 RegO Drive, Elon, N.C. 27244, RegO®, at its option, and within forty-five days of receipt, will repair, replace F.O.B. point of manufacture, or refund the purchase price of that part or product found by RegO® to be defective. Failure of buyer to give such written notice and ship the product within thirty days shall be deemed an absolute and unconditional waiver of any and all claims of buyer arising out of such defect.

This warranty does not extend to any product or part that is not installed and used continuously after installation in accordance with RegO®'s printed instructions, all applicable state and local regulations, and all applicable national standards, such as those promulgated by NFPA, DOT and ANSI. This warranty does not extend to any product or part that has been damaged by accident, misuse, abuse, failure to maintain, or neglect, nor does it extend to any product or part which has been modified, altered, disassembled, or repaired in the field. This warranty does not cover any cosmetic issues, such as scratches, dents, marring, fading of colors or discoloration.

EXCEPT AS EXPRESSLY SET FORTH ABOVE, AND SUBJECT TO THE LIMITATION OF LIABILITY BELOW, REGO® MAKES NO OTHER WARRANTY, AND EXPRESSLY DISCLAIMS, ANY EXPRESS OR IMPLIED WARRANTIES, INCLUDING, BUT NOT LIMITED TO, THE IMPLIED WARRANTIES OF MERCHANTABILITY AND FITNESS FOR A PARTICULAR PURPOSE, WITH RESPECT TO ITS PRODUCTS AND PARTS, WHETHER USED ALONE OR IN COMBINATION WITH OTHERS. REGO® DISCLAIMS ALL WARRANTIES NOT STATED HEREIN.

This Limited Warranty is given by Engineered Controls International LLC, of 100 RegO Drive Elon, NC 27244 USA, (336) 449-7707.

LIMITATION OF LIABILITY

RegO® total liability for any and all losses and damages arising out of any cause whatsoever shall in no event exceed the purchase price of the products or parts in respect of which such cause arises, whether such causes be based on theories of contract, negligence, strict liability, tort or otherwise.

RegO® shall not be liable for incidental, consequential or punitive damages or other losses. RegO® shall not be liable for, and buyer assumes any liability for all personal injury and property damage connected with the handling, transportation, possession, further manufacture, other use or resale of products, whether used alone or in combination

with any other products or materials.

From time to time buyers might call to ask RegO® for technical advice base upon limited facts disclosed to RegO®. If RegO® furnishes technical advice to buyer, whether or not a buyer's request, with respect to application, further manufacture or other use of the products and parts, RegO® shall not be liable for such technical advice or any such advice provided to buyer by any third party and buyer assumes all risks of such advice and the results thereof.

NOTE: Some states do not allow the exclusion or limitation of incidental, consequential or punitive damages, so the above limitation or exclusion may not apply to you. The warranty gives you specific legal rights, and you may have other rights that vary from state to state. The portions of the limited warranty and limitation of liability shall be considered severable and all portions which are not disallowed by applicable law shall remain in full force and effect.

The benefits given by the Limited Warranty above are in addition to any other rights and remedies to which you may be entitled by law.

NOTE TO AUSTRALIAN PURCHASERS: The following applies if you purchased this product as a "consumer" as defined in the Australian Consumer Law. Our goods come with guarantees that cannot be excluded under the Australian Consumer Law. You are entitled to a replacement or refund for a major failure and compensation for any other reasonably foreseeable loss or damage. You are also entitled to have the goods repaired or replaced if the goods fail to be of acceptable quality and the failure does not amount to a major failure. Information regarding how to return a product and make a claim under this Limited Warranty is set forth below.

Nothing in this document purports to modify or exclude your rights if any under the Australian Consumer Law, or other laws which cannot be lawfully be modified or excluded.

WARNING

All RegO® products are mechanical devices that will eventually become inoperative due to wear, corrosion and aging of components made of materials such as rubber, etc. The environment and conditions of use will determine the safe service life of these products. Periodic inspection and maintenance are essential to avoid serious injury and property damage.

Many RegO® products are manufactured components which are incorporated by others on or in other products or systems used for storage, transport, transfer and otherwise for use of toxic, flammable and dangerous liquids and gases. Such substances must be handled by experienced and trained personnel only, using accepted governmental and industrial safety procedures.

NOTICE TO USERS OF PRODUCTS

The Limited Warranty stated above is a factory warranty to the first purchasers of RegO® products. Since most users have purchased these products from RegO® distributors, to make a claim under this Limited Warranty the user must within thirty (30) days after the user's discovery of what user believes is a defect, notify in writing and return the product (at the user's expense) to the distributor from whom he purchased the product/part. The distributor may or may not at the distributor's option choose to submit the product/parts to RegO®, pursuant to this Limited Warranty. Failure by buyer to give such written notice and return the product within thirty (30) days shall be deemed an absolute and unconditional waiver of buyer's claim for such defects. Acceptance of any alleged defective product/parts by RegO®'s distributor for replacement or repairs under the terms of RegO®'s Limited Warranty in no way determines RegO®'s obligations under this Limited Warranty.

Because of a policy of continuous product improvement, RegO® reserves the right to change designs, materials or specifications without notice.



Printed in the U.S.A. REV E 05-1120-0817
Instruction Sheet A3214-302

RegO® is a registered trademark of Engineered Controls International, LLC.