

NELES

Flexible lip seat design for Jamesbury™ ball valves

JAMESBURY FLEXIBLE LIP SEAT DESIGNS

The flexible lip seat design (U.S. Patent in 1954) positioned Jamesbury as a valve industry leader by taking advantage of the chemical compatibility, low friction and high temperature materials in seat design. The Jamesbury flexible lip style seat design is used in all our standard high performance flanged, threaded and weld end valves. These include: Series 7000, Series 9000, Series 4000, Eliminator™ and “A” Style.

The Jamesbury flexible lip seat design is preferred for a wide range of general as well as special services. The design exerts continuous pressure against the ball for reliable sealing while automatically compensating for wear, changes in temperature and pressure excursions.

This flexible lip seat design makes use of the mechanical properties of the seat material and line pressure to increase the effectiveness of the seal while still providing exceedingly high cycle life. The seat geometry features O. D. grooves, heel grooves, and a unique seat lip & heel design. The design of the valve body includes a specific flex zone that allows the seat to flex but also prevents excessive movement that would cause permanent deformation.

This is how our Jamesbury soft-seated valves can provide exceptionally high cycle life and a positive sealing under extreme conditions

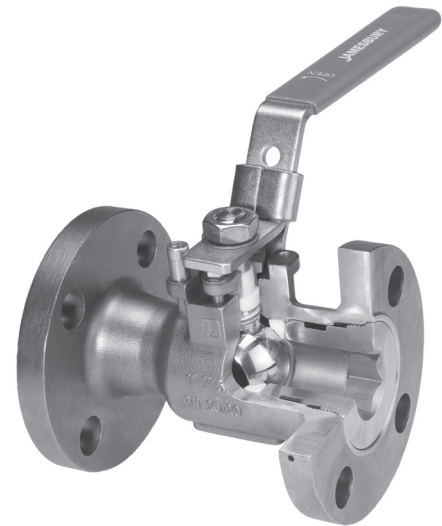
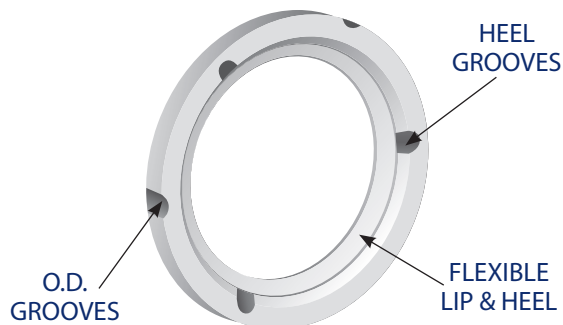

FEATURES

Flexible Lip Seat Designs will:

- Center the ball in the valve cavity
- Allow the ball to float
- Store energy for low-pressure sealing
- Support the ball and pressure forces
- Provide cavity relief
- Reduce Actuator size by reducing Torque
- Provide bubble tight shut-off. Exceeding ANSI/FCI 70-2 Class 6
- Provide extremely high cycle life

Effect of Geometry and Material on Seat Recovery

In terms of geometry, the best way to design for optimal recovery is to limit the magnitude of the stresses in the seat under pressure. The higher the stress level, the greater the risk of inelastic, or non-recoverable, deformation.

The best way to reduce the overall stress level is to allow the seat room to move or flex as the ball is pressed into it under pressure. This is the basic design concept of the Jamesbury brand flexible lip geometry.

Conventional jam seats cannot shift position to accommodate pressure from the ball, and therefore, will develop higher stress leading to less recovery.

CAVITY RELIEF

The flexible lip design relieves cavity pressure to the high pressure side and, in instances where line pressure does not exist, the seats will relieve into the piping system. This is accomplished by designing characteristics into the seat that allow for relief to take place. O.D. grooves allow pressure into the valve cavity that help to reduce torque and allow the ball to float into the down stream seat.

Grooves in the heel of the seat allow trapped pressure in the valve cavity to the flexible sealing lip. The combination of these features and a correctly designed seat will provide bubble tight sealing and cavity pressure relief. The illustrations below show how this seat design works.

ANSI B16.34 Para 2.3.3 “Thermal Fluid Expansion”

“It is the responsibility of the user to provide or require to be provided, means in design, installation or operation procedure to assure that pressure in the valve will not exceed that allowed by this standard for the attained temperature.”

~ Standard with Jamesbury flexible lip seat design valves. ~

Fig 1.

When trapped, process fluid is subject to pressure increases. *Jamesbury's* flexible lip seat design will relieve cavity pressure without damaging the valve. This condition takes advantage of the heel grooves to provide relief.

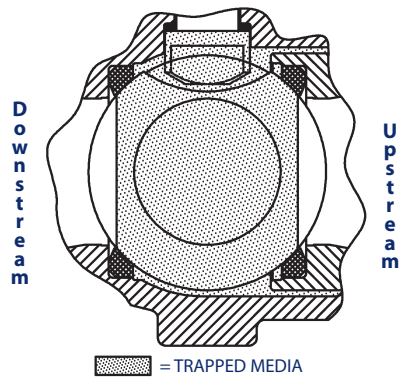

Fig 1.

Fig 2.

With upstream line pressure, the cavity pressure relief takes the path of least resistance. *Jamesbury's* upstream seat flexes outward to release expanded fluids. Here the O.D. grooves allow for cavity pressure and again the heel grooves on the upstream seat will flex to provide relief.

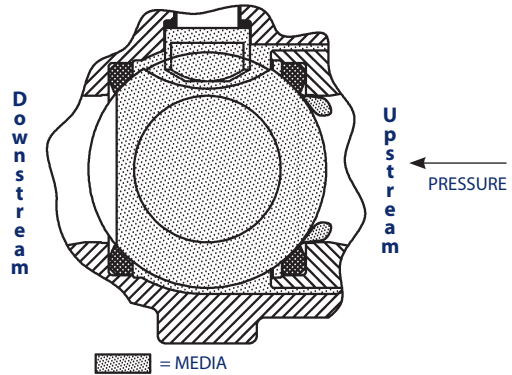

Fig 2.

Fig 3.

Without line pressure, cavity relief is achieved when both *Jamesbury's* seats flex outward to release expanded fluids. This condition also takes advantage of the heel grooves to provide relief by relieving the pressure into the piping system.

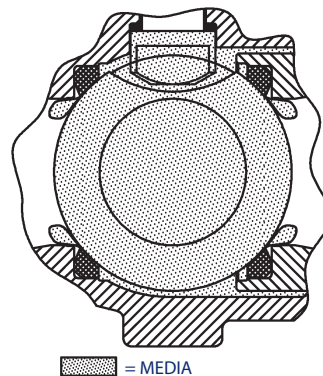

Fig 3.

BALL/STEM VENT HOLE

Neles decided to provide as standard a vented ball (small internal port located at the slot in the ball at the point where the stem engages) on all ball valves.

This feature is designed to equalize pressure between the media flowing through a fully open valve and the volume adjacent to the ball, inboard of the seats (also known as the ball cavity).

The purpose of the vent hole is to add additional relief with the valve in the full open position. The vent hole has no effect on bi-directional sealing and is provided at no additional cost.

We are continuously improving all of the Jamesbury products. The vented ball is one improvement that is being incorporated throughout the product lines.

TRUNNION SEAT DESIGN

Trunnion designs are available in 6" and larger full port valves and 8" and larger standard port valves. Trunnions reduce the amount the ball is allowed to float from the forces developed from line pressures, they support and center the ball, maintain the ball position and retain the seats. Trunnions also reduce required operating torque, which leads to a smaller actuation.

The seats design in a trunnion style valve incorporates the same patented flexible lip design used with the floating ball seats. The trunnion seats offer the same tight low pressure sealing, cavity relief, long cycle life and protection against pressure/temperature excursions, as does the floating ball seats.

TEST SPECIFICATIONS AND CONFORMANCE

All Jamesbury brand valves, including our standard non-live loaded valves, conform to the leakage requirements as outlined by 46CFR60 METHOD 21 of the Clean Air Act. All 7000 and 9000 series valves and all ANSI rated series 4000 and Eliminator Model "B" valves are 100% hydrostatic shell tested, porosity tested and seat tested, in accordance with API 598 before they leave the factory. The acceptance standard is no leakage (bubble tight) for the measured duration of the testing.

In summary, the flexible lip seat geometry provides the optimum seat for maximum recovery.

PRODUCTS

Series 7000	–	See Bulletin B107-1
Series 9000	–	See Bulletin B107-2
Series 4000	–	See Bulletin B105-1
<i>Eliminator</i>	–	See Bulletin B101-2
"A" Style	–	See Bulletin B100-1

Neles

Vanha Porvoontie 229, 01380 Vantaa, Finland.
Tel. +358 10 417 5000.

neles.com

B100-0EN - 11/2020

Subject to change without prior notice. Neles, Jamesbury and Easyflow by Neles, and certain other trademarks, are either registered trademarks or trademarks of Neles Corporation or its subsidiaries or affiliates in the United States and/or in other countries. For more information www.neles.com/trademarks

Reinventing
reliability