



## Maintenance Manual

# 2½" Flanged Super Maxi Rail Relief Valve: AAR

Part Number: 0R3/XXXX006X

**This is an uncontrolled copy that will not be updated automatically.  
Please refer to Fort Vale for document revisions.**





# CONTENTS

## 2½" Flanged Super Maxi Rail Relief Valve

### Maintenance Manual

	Introduction	3
	Maintenance Safety Precautions	4
<b>Chapter 1</b>	Disassemble the Valve	5
<b>Chapter 2</b>	Assemble the Valve	11
<b>Chapter 3</b>	Test & Adjust the Set Pressure	17
<b>Chapter 4</b>	Install the Andi-Tamper Screw	23
<b>Appendix</b>		27
A	Tools & Equipment	28
B	Bolt Torque Guide & Step Loading Procedure	29
C	Client Responsibilities	31
D	Data Sheet: USREL147 2½" Flanged Super Maxi Rail Relief Valve	33
E	Data Sheet: USREL185 Part Number Breakdown - 0R3/XXXX006X	35







# 2½" Flanged Super Maxi Rail Relief Valve

## Maintenance Manual - Introduction

---

### IMPORTANT

Read all the information and instructions before you start the procedure. Keep this manual.

**WARNING:** A relief valve is a spring-loaded device which can cause serious injury to personnel. Obey all the maintenance and safety precautions.

### Overview

This maintenance manual contains instructions to do the maintenance and testing on a 2½" flanged Super Maxi rail relief valve, part number series 0R3/XXXX006X.

**SPECIFICATION CHANGE:** From January 2024, the shape of the body flange changed from Ø7.5" round to 6" A/F square. The valve properties are the same, this includes the number of holes and size, PCD, flange thickness and the size and length of fasteners.

The valve shown in this manual is part no. 0R3/X165006R with a set pressure of 165 PSIG and a round raised face flange.

### Maintenance Precautions

To prevent injury to personnel:

- be careful during maintenance.
- obey all warnings.
- use the recommended tools.
- use the applicable PPE.

To prevent damage to the valve:

- use the recommended tools to do the maintenance and to test the valve.
- obey the recommended bolting sequence and Step Loading Procedure when you remove and install the valve (see Appendix B: Bolt Torque Guide & Step Loading Procedure).
- read Client Responsibilities (see Appendix C).
- use genuine Fort Vale spare parts.

### Tools & Equipment

You will need general workshop equipment and hand tools and some special tools to do relief valve maintenance. Please refer to Appendix A: Tools & Equipment.

### Replacement Parts

Identify your relief valve - the part number series will be marked on the valve cap. Please contact Fort Vale to order new seal kits and replacement parts. Install only genuine spare parts.

**WARNING:** If you install a replacement part that is not a genuine Fort Vale part, there is a risk of:

- injury to personnel.
- valve malfunction.
- permanent damage to the valve or tank.

### Technical Support

If you find a problem with the valve that you cannot correct, please contact Fort Vale.

### Disclaimer

Fort Vale reserves all rights to make technical modifications and improvements at any time. Fort Vale accepts no responsibility for any consequences arising from the use of the valve/ancillary and these instructions. Errors and omissions excepted.



## Important Safety Notice

**WARNING:** Vessels and systems operate under pressure and can contain dangerous cargo (liquid and vapour) that can cause death or serious injury to personnel.

### Precautions

Before you remove a valve from the vessel/system, you must:

- do a Hazard Identification and Risk Assessment.
- make sure the vessel/system is empty (liquid and vapour).
- make sure the vessel and valves have been cleaned correctly.
- make sure the vessel has been certified safe for human entry.
- make sure that the vessel/system pressure is at zero. When all the vessel/system pressure is released, use an approved method to release all residual pressure before you loosen the fasteners.
- read the SDS (Safety Data Sheet) for the last cargo and obey the recommended precautions.
- use the applicable PPE (Personal Protection Equipment) for the cargo and operating conditions.

### Approved Person

You must be an “approved person” to do valve maintenance and testing. An approved person:

- knows the function of the valve.
- knows how the valve is assembled, installed and operated.
- knows the operation limits of the valve.
- has experience and qualifications related to valve maintenance and testing.
- knows and obeys all the related in-company and regional/national regulations.

### After Maintenance

When the maintenance is completed, use an approved method to do these tests to the valve before you install it onto a vessel:

- test for correct operation.
- leak test.



---

# CHAPTER 1

## Disassemble the valve

### 2½" Flanged Super Maxi Rail Relief Valve

---

This chapter contains instructions to fully disassemble the valve and the pressure plate assembly.

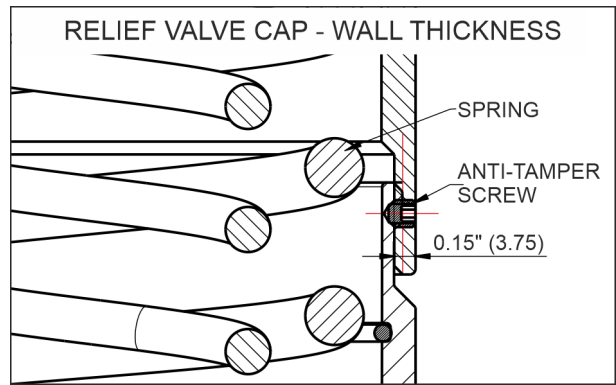

**Step 1.** Identify the valve. The part number will be laser marked on the cap. If you are unsure please contact Fort Vale.

**WARNING:** Relief valves are spring-loaded and can cause serious personal injury. Obey all the instructions and wear eye protection during this procedure.

**Step 2.** The cap is locked to the valve body with an anti-tamper screw filled with lead shot. Note the wall thickness of the relief valve cap.

**CAUTION:** It is important not to drill fully through the cap and body because it can cause damage to the spring.



**Step 3.** Put the valve on a V block on a pedestal drill. Use a No 22 (4mm) drill and drill to a depth of 0.2" (5mm) to remove the lead shot and screw. This will unlock the cap.

**CAUTION:** Do not drill to a depth of more than 0.2" (5mm) to prevent damage to the spring.

**Step 4.** Clean the hole using compressed air.



**Step 5.** Use a sharp-edged tool to detach the stainless steel plug.



**Step 6.** Remove the stainless steel plug. Keep the plug.



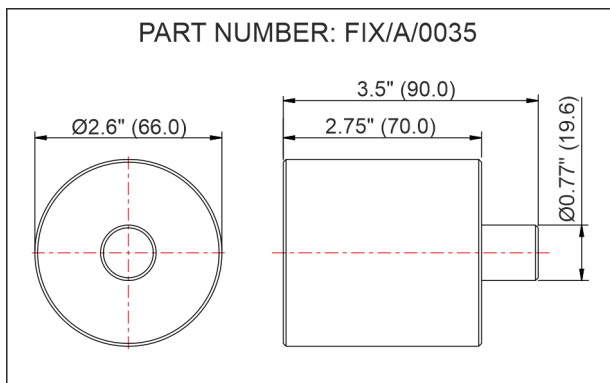

**Step 7.** Select the nylon lifting spacer, part number FIX/A/0035.

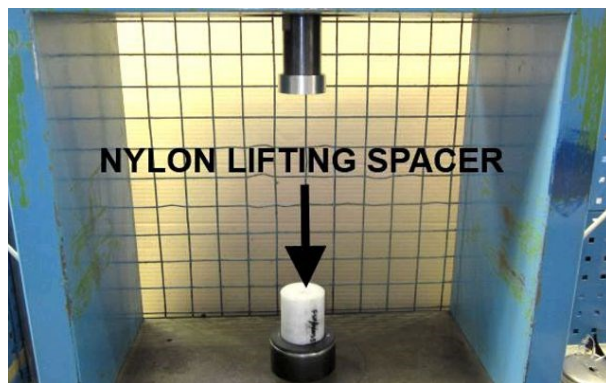

**Step 8.** Install the nylon lifting spacer onto a bench press with a minimum 1 tonne load.



**Step 9.** Install the valve onto the spacer. Make sure that the valve is central on the spacer.



**Step 10.** Select the cap tightening tool, part number FIX/A/0034. Engage the two pins on the cap tightening tool into the two blind holes of the top cap.



**Step 11.** Make sure that the cap tightening tool is installed correctly on the cap.



**Step 12.** Apply pressure onto the top cap tightening tool until the spring is compressed enough so that the valve body is free to move. Then turn the valve body clockwise until it is disassembled from the top cap.

**WARNING:** Make sure that you lock the press before you start to unscrew the valve.



**Step 13.** When the valve and the cap are disassembled, unlock the press and gradually retract the press to release the spring load.

**WARNING:** Be careful when you retract the press. Make sure that the spring is fully decompressed before you remove the ram.

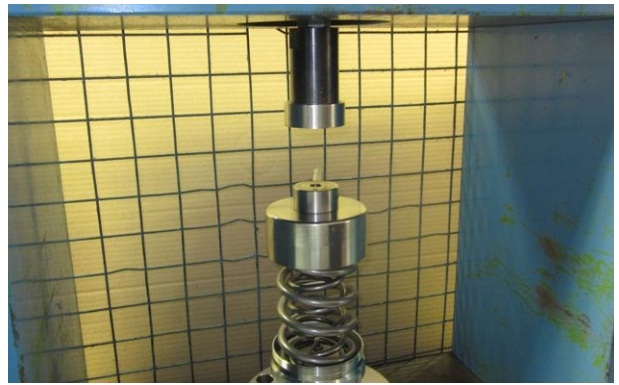

**Step 14.** When the spring is fully decompressed, retract the ram fully.



**Step 15.** Remove the cap tightening tool.



**Step 16.** Remove the top cap. Examine the top cap for signs of damage or wear. If there is damage, contact Fort Vale.



**Step 17.** Remove the springs. Examine the springs for signs of corrosion or damage.

**NOTE:** We recommend that you also do a surface crack test to the spring. If the spring shows signs of pitting, cracking or other linear discontinuity, replace it. Please contact Fort Vale for a replacement spring.



**Step 18.** Remove the valve body and pressure plate from the press and put it onto a work bench.

**NOTE:** Valves manufactured after March 2017 have a retaining ring clip installed in a groove in the valve body.





**Step 19.** Use a sharp-edged tool to release the retaining ring clip from the groove. Remove the clip.



**Step 20.** Remove the pressure plate assembly.



**Step 21.** Examine the body for signs of damage or corrosion. Look carefully at the pressure plate sealing face and the gasket sealing face. If there is damage, contact Fort Vale.



**Step 22. DISASSEMBLE THE PRESSURE PLATE:**  
Use a 1/2" (13mm) spanner to loosen the 5/16" UNF nut on the pressure plate assembly.



**Step 23.** Remove the 5/16" UNF stud and nut.

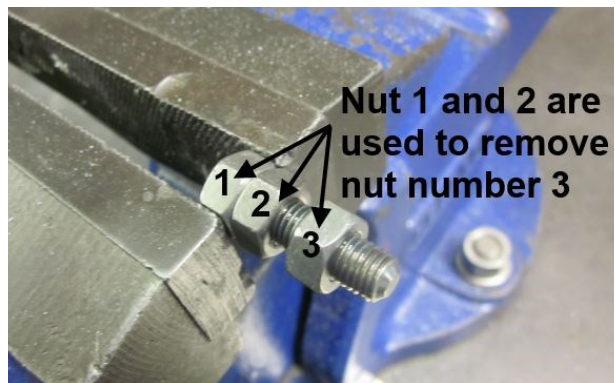

**Step 24.** Use a 1/2" (13mm) spanner to remove the 5/16" nut from the stud. If you cannot move the nut, use 2x 5/16" nuts as shown to prevent damage to the thread: Hold nut 1 in a vice and tighten nut 2. Unlock nut 3 by turning it clockwise and anti-clockwise. Remove nut 3.



**Step 25.** Use a wire brush to clean any remaining adhesive from the stud. Examine the thread on the stud. If there is damage, replace the stud.



**Step 26.** To disassemble the inner and outer pressure plate, insert a 3/16" diameter rod into the hole in the inner pressure plate. Gently tap the rod with a hammer. Remove the retaining washer.

**CAUTION:** Take care not to cause damage. Do not let the inner pressure plate fall.



**Step 27.** Examine the inner pressure plate and the washer for signs of damage or corrosion. If there is damage, contact Fort Vale.



**Step 28.** Remove the O ring and discard it. Inspect the outer pressure plate for signs of damage or corrosion. If there is damage, contact Fort Vale. The disassembly procedure is complete.





---

# CHAPTER 2

## Assemble the valve

### 2½" Flanged Super Maxi Rail Relief Valve

---

This chapter contains instructions to assemble the pressure plate and to fully assemble the valve.



**Step 29. ASSEMBLE THE PRESSURE PLATE:**  
Clean all pressure plate components and examine them for signs of damage or corrosion. If there is damage, contact Fort Vale.

- 1. 5/16"UNF x 30mm stud;
- 2. 5/16"UNF nut;
- 3. Retaining washer;
- 4. Inner pressure plate;
- 5. O ring;
- 6. Outer pressure plate.

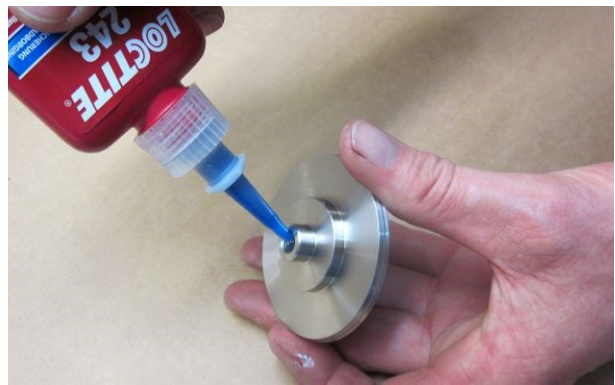

**Step 30** Apply thread adhesive to the thread of the inner pressure plate.



**Step 31.** Install the 5/16" UNF stud and tighten it.

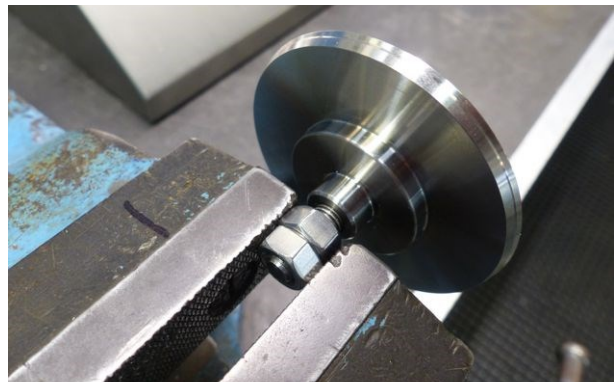

**Step 32.** It is important to fully tighten the stud/pressure plate assembly: Install 2x 5/16" nuts onto the stud. Hold the nuts in a vice to avoid damage to the thread. Tighten the pressure plate by hand. Remove the assembly from the vice and remove the 2x nuts.



**Step 33.** Install a new O ring into the outer pressure plate seal groove. Make sure that the O ring is fully installed around its circumference.

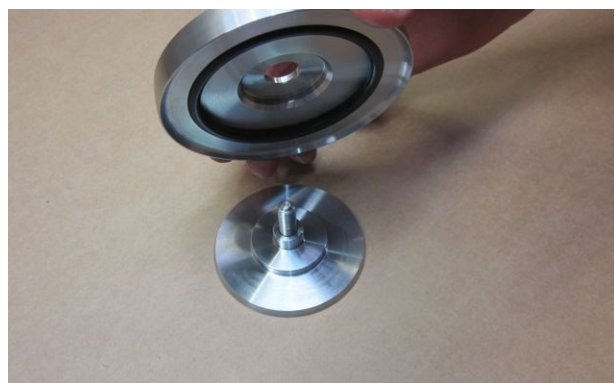

**Step 34.** Assemble the outer pressure plate onto the inner pressure plate assembly.



**Step 35.** Make sure that the O ring is correctly installed. The O ring must be held equally around its circumference by the inner pressure plate.

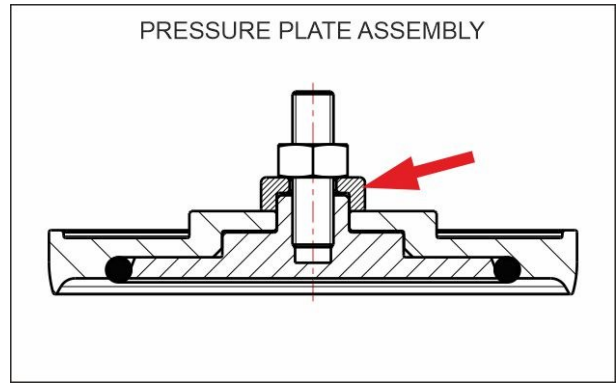

**Step 36.** Note the correct orientation of the retaining washer.



**Step 37.** Install the retaining washer.

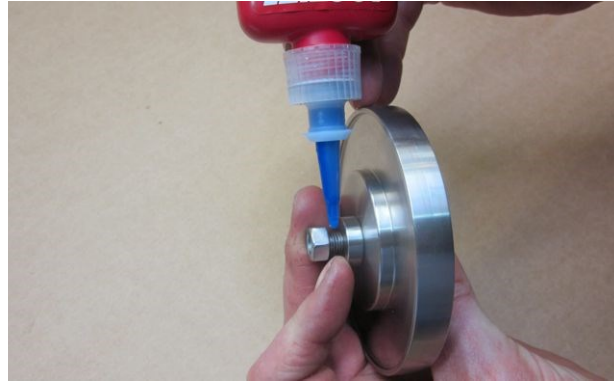

**Step 38.** Apply thread adhesive to the thread of the stud and install the nut.



**Step 39.** Use a 1/2" (13mm) torque wrench to tighten the nut to a torque of 15 ft.lbs (20 Nm).



**Step 40.** The assembly of the pressure plate is complete.





**Step 41. ASSEMBLE THE VALVE:**

Clean the body. Examine the body for signs of damage or corrosion. Look carefully at the pressure plate sealing face and the gasket sealing face. If there is damage, contact Fort Vale.



**Step 42.** Install the pressure plate assembly into the body.



**Step 43.** If the valve has a retaining ring clip, install it into the body and push it into the groove. Make sure it is fully installed around the circumference. If the valve has no ring clip, go to Step 44.

**CAUTION:** Be careful - spring-loaded part.



**Step 44.** Examine the springs for signs of damage or corrosion. If satisfactory, install the springs.

**NOTE:** We recommend that you also do a surface crack test to the spring. If the spring shows signs of pitting, cracking or other linear discontinuity, replace it. Please contact Fort Vale for a replacement spring.



**Step 45.** Apply thread lubricant that is compatible with stainless steel on the thread of the top cap. Lubrication helps the threads to engage between the body and the cap.



**Step 46.** Install the top cap onto the springs. Make sure that the springs engage into the groove inside the cap. To complete the assembly procedure, move the valve to a bench press with a minimum 1 tonne load.

**WARNING:** Relief valves are spring-loaded and can cause serious personal injury. Obey all the instructions and wear eye protection during this procedure.

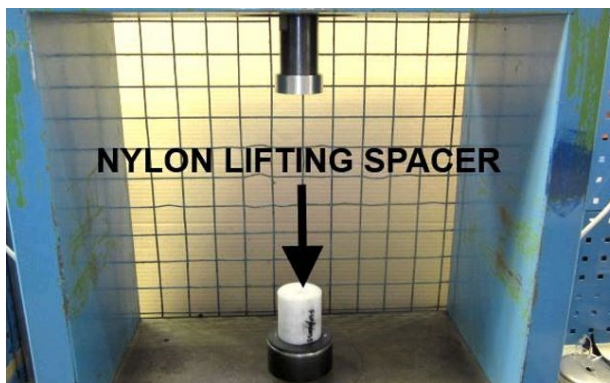

**Step 47.** Select the nylon lifting spacer, part number FIX/A/0035 and install it onto the bench press. Make sure that the ram is retracted to allow enough space to accept the valve height.



**Step 48.** Install the valve onto the spacer. Make sure that the valve is central on the spacer.



**Step 49.** Select the cap tightening tool, part number FIX/A/0034. Engage the two pins on the cap tightening tool into the two blind holes of the top cap.



**Step 50.** Make sure that the cap tightening tool is installed correctly on the cap.



**Step 51.** Make sure that the valve assembly is centrally aligned to the ram. Apply pressure slowly onto the top cap to compress the spring.

**CAUTION:** Align the body with the cap to prevent cross-threading.



**Step 52.** Stop the press when there is a gap of approx. 1/8" (2-3mm) between the top cap and the valve body. Lift the valve body and rotate it anti-clockwise to engage the threads between the valve body and the top cap. Continue to screw the body fully into the cap until there are no threads visible.

**WARNING:** Make sure that you lock the press.





**Step 53.** When the top cap and valve are fully engaged, release pressure from the top ram.

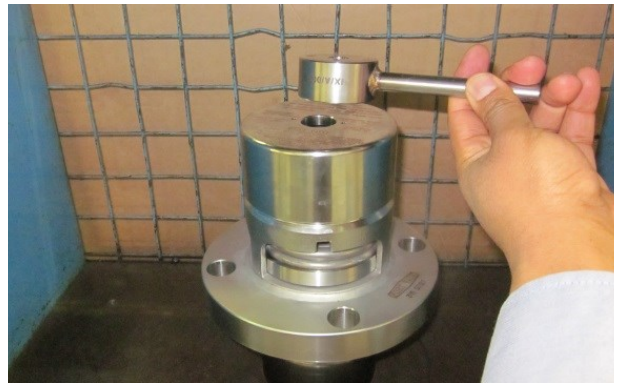

**Step 54.** Remove the cap tightening tool. The assembly procedure is complete.  
NOTE: You must do the pressure test and adjustment procedure before you install the valve onto the tank. Refer to Chapter 3.



---

# CHAPTER 3

## Test and adjust the set pressure

### 2½" Flanged Super Maxi Rail Relief Valve

---

This chapter contains instructions to test the set pressure of the relief valve and to make small adjustments to get the correct set pressure.





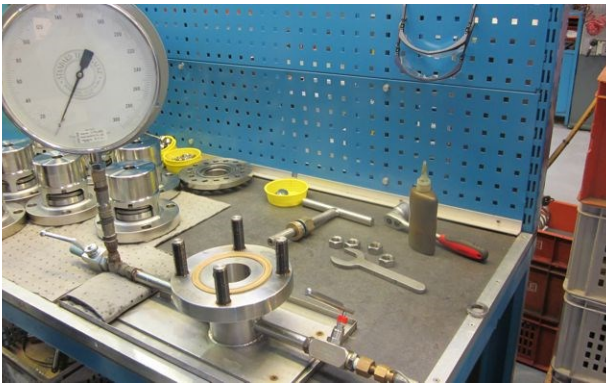

**Step 55.** Do a pressure test procedure that obeys AAR standards:  
The photo shows a typical pressure test rig. You can buy a test rig from Fort Vale.

**WARNING:** You must be an approved person to test and set relief valves. Spring-loaded valves can cause serious personal injury.



**Step 56.** Install the valve onto the 4x studs on the test rig flange.



**Step 57.** Install 4x compatible washers.



**Step 58.** Install 4x compatible nuts. Tighten the nuts in a diametrically opposite sequence.



**Step 59. PRESSURE TEST:**  
Apply leak detection fluid around the area where the pressure plate touches the body.



**Step 60.** Apply pressure up to the set pressure of the valve and look for bubbles around the pressure plate. Note the pressure at which the bubbles start to occur. This indicates the initial set pressure of the valve. Release the pressure.

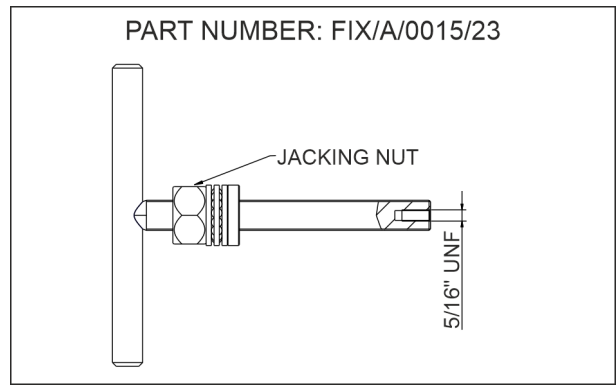

**Step 61. PRESSURE ADJUSTMENT:**

To adjust the valve to the correct set pressure, select the relief valve adjustment tool FIX/A/0015/23. Use a 1½" (38mm) A/F spanner to adjust the jacking nut.

**Step 62.** The adjustment tool has a 5/16" UNF female thread that engages onto the 5/16" stud on the pressure plate. When the tool is installed into the relief valve, you can tighten the jacking nut to lift the pressure plate off the valve sealing face. You can then turn the valve cap to adjust the spring load.

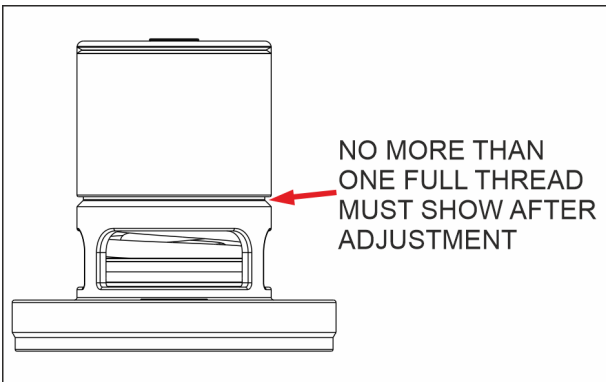

**Step 63. WARNING:** When you turn the valve cap, A MAXIMUM OF ONE FULL THREAD is permitted to show. The cap is holding the spring load. If you turn the cap more, there is a risk of serious injury.

**Step 64. PRESSURE SETTING TOLERANCE:**  
 The tolerance for the set pressure/Start to Discharge (STD) is ±3%. For a set pressure of 75 PSI:  
 Minimum STD pressure = 72.75 PSI  
 Maximum STD pressure = 77.25 PSI  
 For a set pressure of 165 PSI:  
 Minimum STD pressure = 160.1 PSI  
 Maximum STD pressure = 169.95 PSI



**Step 65.** With the jacking nut at the top of the thread, install the relief valve adjusting tool through the hole in the top cap. Engage the female thread of the tool with the pressure plate stud and tighten the tool. Make sure the tool is fully engaged.

**Step 66.** When the tool is fully engaged with the pressure plate, hold the tee bar and use a 1½" (38mm) A/F spanner to tighten the brass jacking nut. This will lift the pressure plate off the sealing face, which allows the cap to turn.

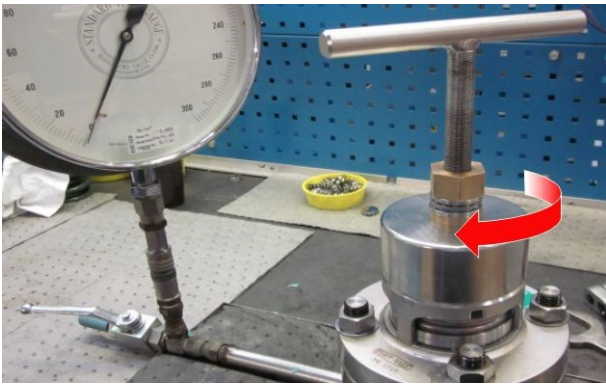

**Step 67. PRESSURE TOO LOW:** If the valve test pressure result was lower than the target set pressure, turn the cap approx. ¼ turn clockwise. Loosen the jacking nut to re-seat the pressure plate. Unscrew and remove the adjustment tool. Do the pressure test again (Step 59 & Step 60).

**WARNING:** Do not turn the cap more than one full thread visible. If you turn it more, there is a risk of serious injury.

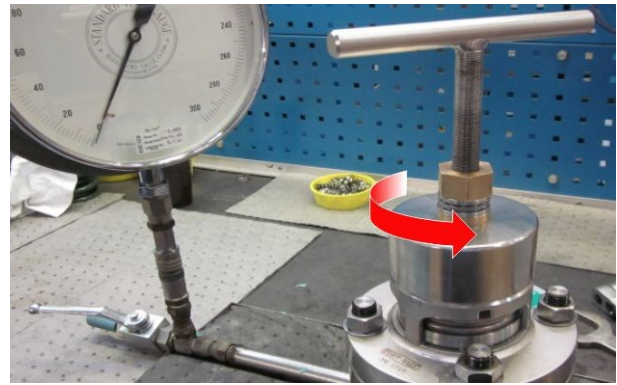

**Step 68. PRESSURE TOO HIGH:** If the valve test pressure result was higher than the target set pressure, turn the cap approx. ¼ turn anti-clockwise. Loosen the jacking nut to re-seat the pressure plate. Unscrew and remove the adjustment tool. Do the pressure test again (Step 59 & Step 60).

**WARNING:** Do not turn the cap more than one full thread visible. If you turn it more, there is a risk of serious injury.



**Information**

**Step 69.** Do the pressure adjustment and the pressure test procedures until you get the correct set pressure.



**Troubleshooting**

**Step 70. TROUBLESHOOTING:** If you cannot get the correct set pressure when one thread shows on the valve body:

Disassemble the valve and turn the spring through 180°. Assemble the valve and do the pressure test and adjustment procedures. Refer to the related chapters for instructions.



**Troubleshooting**

**Step 71. TROUBLESHOOTING:** If turning the spring does not solve the problem, disassemble the valve and install a new spring. Assemble the valve and do the pressure test and adjustment procedures. Refer to the related chapters for instructions.



**Step 72. RE-SEAL PRESSURE TEST:** When the set pressure is satisfactory, reduce the test rig pressure by approx. 10% (68 PSI for a 75 PSI valve or 150 PSI for a 165 PSI valve).

Apply leak detection fluid and make sure there is no leakage. Leakage is identified by small bubbles around the pressure plate. There must be no leakage for 30 seconds.





## Information

### Step 73. RE-SEALING TOLERANCE:

The maximum tolerance for the re-sealing pressure/vapor tight pressure (VTP) is 80% of the set pressure.

For a set pressure of 75 PSI:

Minimum re-seal pressure/VTP = 60 PSI

For a set pressure of 165 PSI:

Minimum re-seal pressure/VTP = 132 PSI



**Step 74.** When the valve is set pressure/re-seal pressure is satisfactory, do the pressure test and re-seal test again to make sure you get the same result. If the result is satisfactory, release the pressure from the test rig.

**CAUTION:** Make sure that all pressure is released and the pressure supply is off before you remove the valve.



**Step 75.** Install the stainless steel plug.



**Step 76.** Dry the valve and the test rig. Remove the 4x nuts and washers and remove the valve from the test rig. You must install the anti-tamper screw to lock the valve before you install the valve onto a tank. Refer to Chapter 4.



---

# CHAPTER 4

## Install the anti-tamper screw

### 2½" Flanged Super Maxi Rail Relief Valve

---

This chapter contains instructions to lock the relief valve when all the test results are satisfactory.



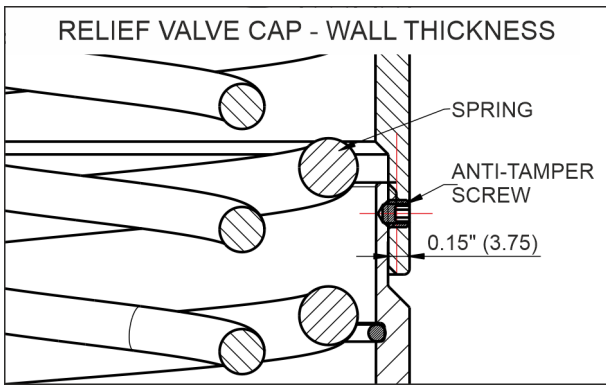

**Step 77. INSTALL THE ANTI-TAMPER SCREW:** The cap is locked to the valve body with an anti-tamper screw filled with lead shot. Note the wall thickness of the relief valve cap.

**CAUTION:** It is important not to drill fully through the cap and body because it can cause damage to the spring.

**Step 78.** Put the valve on a V block on a pedestal drill. Use a No 22 (4mm) drill and use the existing hole in the cap. Drill to a depth of 0.2" (5mm).

**CAUTION:** Do not drill to a depth of more than 0.2" (5mm) to prevent damage to the spring.

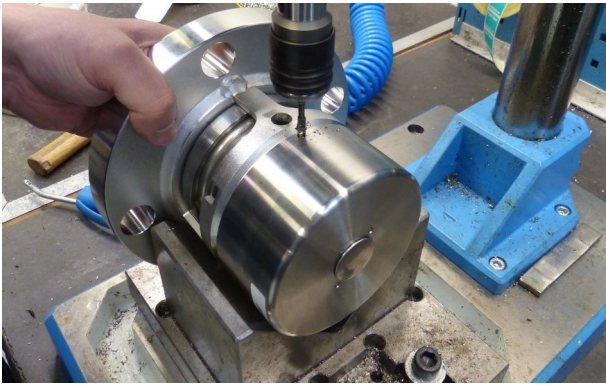

**Step 79.** Use a 3/16" BSW tap and tap the hole to a depth of 0.14" (3.5mm).

**CAUTION:** Do not tap to a depth of more than 0.14" (3.5mm) to prevent damage to the spring.

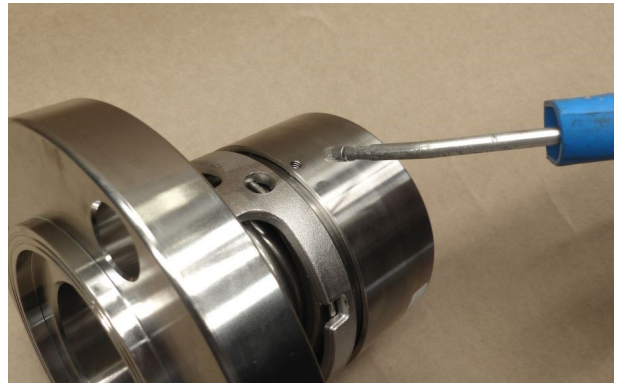

**Step 80.** Clean the hole using compressed air.



**Step 81.** Install a 3/16" x 3/16" long socket head screw. Use a 3/32" hex key to turn the screw until it is recessed in the cap.



**Step 82.** Put a 1/8" lead shot into the top of the screw.

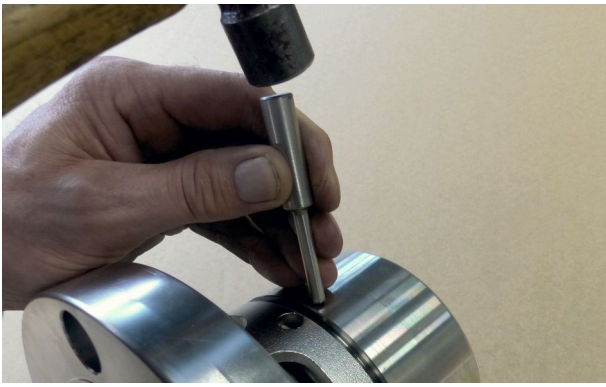

**Step 83.** Using a pin punch, lightly tap the pin punch with a hammer to compress the shot and seal the screw.

**CAUTION:** Do not use too much force. Too much force will cause damage to the valve.



**Step 84.** The procedure is complete.

Make sure that the information that is marked on the cap matches the specification of the valve. If you do not wish to install the valve immediately, seal the valve in a clean plastic bag.





---

# APPENDIX

## 2½" Flanged Super Maxi Rail Relief Valve

### Maintenance Manual

---

A	Tools & Equipment	28
B	Bolt Torque Guide & Step Loading Procedure	29
C	Client Responsibilities	31
D	Data Sheet: USREL147 2½" Flanged Super Maxi Rail Relief Valve	33
E	Data Sheet: USREL185 Part Number Breakdown - 0R3/XXXX006X	35



## 2½" Flanged Super Maxi Rail Relief Valve Maintenance Manual - Tools & Equipment

### General Tools & Equipment

You will need these general tools to do maintenance on a 2½" Flanged Super Maxi Relief Valve 0R3/XXXX006X:

Scribe/small screwdriver

3/32" hex key

Compressed air - dry & filtered

Clean cloth

Thread lubricant (compatible with stainless steel) e.g. Rocol®

Leak detection fluid

15/16" (24mm) A/F spanner

1½" (38mm) A/F spanner

⅛" lead shot

Pin punch

Hammer

Pedestal drill with No.22 (4mm) drill and 3/16" BSW tap

Bench press - 1 tonne load minimum

**WARNING:** Spring-loaded valves can have a load of up to 1 tonne. Make sure that your press is compatible with this load.

### Special Tools

You will need these special tools to do maintenance on a 2½" Flanged Super Maxi Relief Valve 0R3/XXXX006X. You can buy all the special tools from Fort Vale.

Cap tightening tool, part number FIX/A/0034

Nylon lifting spacer, part number FIX/A/0035

Relief valve adjusting tool, part number FIX/A/0015/23

Relief valve test rig - see NOTE below.

**NOTE:** We recommend that you use a Fort Vale Relief Valve Test Rig. However, if you already have a test rig, we recommend that you obey these precautions:

#### Test Rig Precautions

##### Compressed air supply conditions:

- The compressed air must be clean, dry and filtered.
- Regularly clean and do the servicing of the filters, downstream pipework and compressor.
- The compressed air supply pipes must have a minimum internal diameter of 3/16" (4mm).
- The compressed air supply pressure must be a minimum of 15 PSI (1 Bar) higher than the test pressure of the valve.

##### Test rig pressure/vacuum gauges:

- Calibrate the gauges to AAR requirements.
- Obey the maximum allowable pressure on the gauge(s) and do not apply more than the allowed pressure.
- Do not apply pressure to a vacuum gauge.
- The pressure and vacuum gauges and the valve test port must not be more than 9.75" (250mm) away from each other.



# Bolt Torque Guide & Step Loading Procedure (US)

## Installation & Operating Instructions

### Flange Bolting

**CAUTION:** Weld-distortion and too much tightening force will cause damage to a flange.

It is important not to cause damage to weld-in flanges and mating flanges. If a flange is damaged it will not give a satisfactory seal when a gasket and secondary mating flange is installed.

Bolt-stress can decrease after initial tightening. The cause can be deformation of the gasket material, particularly with soft materials such as a CNAF/PTFE envelope gasket.

Best procedure recommends that, after initial bolting, the flange joint is tightened again after a period of time. Most gasket manufacturers advise a period of 24 hours. ASME PCC-1-2000 GUIDELINES FOR PRESSURE BOUNDARY BOLTED FLANGE JOINT ASSEMBLY advises a minimum period of 4 hours.

Bolt torque calculations are based on a flat flange to within 0.006".

Recommended bolt torque values will be reduced if a lubrication is used.

### Bolt Torque

#### Bolt Torque Values

Fort Vale bolt torque values are given as a reference guide only and are based on:

- the use of a CNAF/PTFE gasket.
- unlubricated fasteners.
- a flange flat to within 0.006".

**CAUTION:** If you use a different gasket material, a lubricant or a flange with distortion, you must re-calculate the torque value.

#### Bolt Torque Procedure

To install flanged parts correctly:

- Examine the mating flange of the part.
- If the flange is marked with a torque value, obey that torque value.
- If there is no torque value marked on the mating flange, obey the bolt torque values given in Table BT1.
- Tighten the bolts evenly in sequence. Refer to Figure BT1.
- Obey the Step Loading Procedure (ASME PCC-1-2000). Refer to the next page.

Table BT1

Thread	Torque Value
3/8"	22 lbf.ft
1/2"	48 lbf.ft
5/8"	60 lbf.ft

Figure BT1

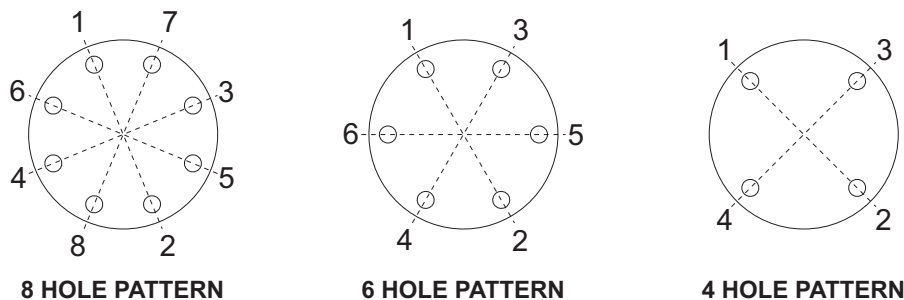



# Bolt Torque Guide & Step Loading Procedure (US)

## Installation & Operating Instructions

---

### Step Loading Procedure

To install flanged parts correctly, obey the Step Loading Procedure extract from ASME PCC-1-2000:

#### Install

Hand tighten, then “snug up” to 10 lbf.ft to 20 lbf.ft (not to exceed 20% of Target Torque).

Check flange gap around circumference for uniformity. If the gap around the circumference is not reasonably uniform, make the appropriate adjustments by selective tightening before proceeding.

#### Round 1

Tighten to 20% to 30% of Target Torque. Check flange gap around circumference for uniformity. If the gap around the circumference is not reasonably uniform, make the appropriate adjustments by selective tightening before proceeding.

#### Round 2

Tighten to 50% to 70% of Target Torque. Check flange gap around circumference for uniformity. If the gap around the circumference is not reasonably uniform, make the appropriate adjustments by selective tightening before proceeding.

#### Round 3

Tighten to 100% of Target Torque. Check flange gap around circumference for uniformity. If the gap around the circumference is not reasonably uniform, make the appropriate adjustments by selective tightening before proceeding.

#### Round 4

Continue tightening the bolts, but on a rotational clockwise pattern until no further nut rotation occurs at the Round 3 Target Torque value. For indicator bolting, tighten bolts until the indicator rod retraction readings for all bolts are within the specified range.

#### Round 5

Time permitting, wait a minimum of 4 hr and repeat Round 4; this will restore the short-term creep relaxation/embedment losses. If the flange is subjected to a subsequent test pressure higher than its rating, it may be desirable to repeat this round after the test is completed.



## Client Responsibilities - Valves & Accessories for AAR

### Installation, Operation & Maintenance Instructions

---

### Compatibility

Make sure that the function and technical specification of the valve/accessory is compatible with the vessel service conditions and the cargo. This includes, but is not limited to:

- dimensions.
- pressure/vacuum setting.
- air/vapor/liquid flow capacity.
- maximum allowable working pressure.
- test pressure.
- minimum/maximum design temperatures.
- materials of construction.

### Maintenance and Inspection

Fort Vale valves and accessories have a long life if you use them correctly in compatible service conditions. It is not necessary to lubricate the parts, but we recommend that you do the inspections that follow:

#### Inspections at regular intervals:

1. Examine the valve to make sure there is no damage, wear or corrosion.
2. Examine the valve and adjacent area to make sure there is no leakage of cargo.
3. Examine the fasteners to make sure they are not loose.
4. Make sure the valve operates correctly.

**CAUTION:** If you operate the valve with very corrosive cargo, or near its temperature and/or pressure limit (very high or very low temperature and/or pressure), do the inspections more frequently.

Also, schedule maintenance at intervals that obey AAR's specification.

### Replacement Parts

Do not adapt or change the valve. If you install a replacement part, it must be a genuine Fort Vale part.

**WARNING:** If you install a part that is not genuine, there is a risk of:

- injury to personnel.
- permanent damage to the valve.
- permanent damage to the vessel.
- valve malfunction.

### External Fire

If you install the valve in an area where there is a risk of external fire, you must install compatible accessories to prevent damage to the valve.

### Compatibility of Accessories

Accessory components must cause no interference with the valve's function. Accessories must be made from compatible materials that will cause no damage to the valve materials. Do not install an accessory that will cause an increased load on the valve, such as mechanical, static, dynamic or thermal load.

### Mis-use

Obey the instructions and recommended procedures in the installation and operating instructions. Obey the pressure and temperature markings on the valve and on the drawing. Use the valve/accessory for its correct function only. Fort Vale accept no liability or responsibility for incorrect use of the valve/accessory.





# 2 1/2" Flanged Super Maxi Relief Valve: AAR

Part No: 0R3/XXXX006X



## Specification

### Nominal size

2 1/2" (DN65)

### Tank connection

Flanged: tongue and groove or raised face in 2 sizes:  
 6.0" A/F drilled 4 x 0.87" holes equi-spaced on a 6.25" PCD  
 Ø12.0" drilled 8 x 0.75" holes equi-spaced on a 10.3" PCD

### Set pressure

Standard settings: 75 PSI & 165 PSI

### Materials

Contact parts: 316 stainless steel  
 Standard pressure O ring: Viton A, Viton B or Viton GFLT

Alternatives are available, please contact Fort Vale

## Design Conditions

Weight: 14 to 34 Lb **Note 1**  
 Design Pressure (MAWP): 165 PSIG  
 Test Pressure: 283 PSIG  
 Design Temperature Min/Max: **Note 2**

**NOTE 1:** The valve specification changes the weight.  
**NOTE 2:** The seal material changes the design temperature.  
 Please refer to Fort Vale for more information.

### Design Code

AAR M1002

AAR Application No: PRD232129

## Range

Description	Part No.
6.0" A/F tongue & groove flange	0R3/XXXX006T
6.0" A/F raised face flange	0R3/XXXX006R
Ø12.0" tongue & groove flange	0R3/XXXX006S
Ø12.0" raised face flange	0R3/XXXX006V

## Valve Height: Refer to Section View

Set Pressure	Valve Height in Inches			
	Dim.T	Dim.R	Dim.S	Dim.V
75 PSIG	4.43"	4.42"	4.83"	4.86"
165 PSIG	5.51"	5.50"	5.91"	5.86"

## Section View

Part No: 0R3/XXXX006T - 6" A/F Tongue & groove flange

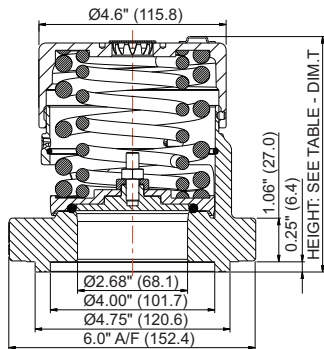

Part No: 0R3/XXXX006R - 6" A/F Raised face flange

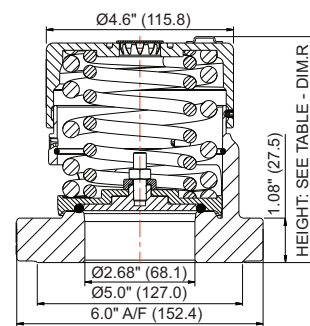

Part No: 0R3/XXXX006S - 12" Tongue & groove flange

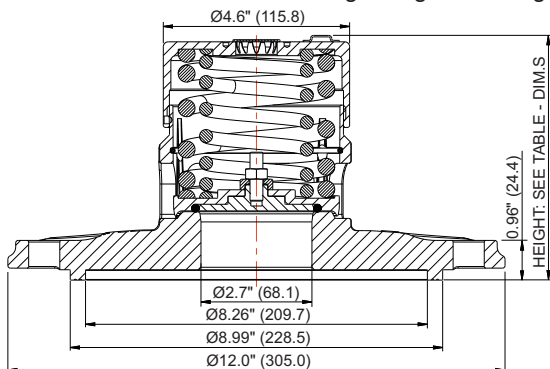

Part No: 0R3/XXXX006V - 12" Raised face flange

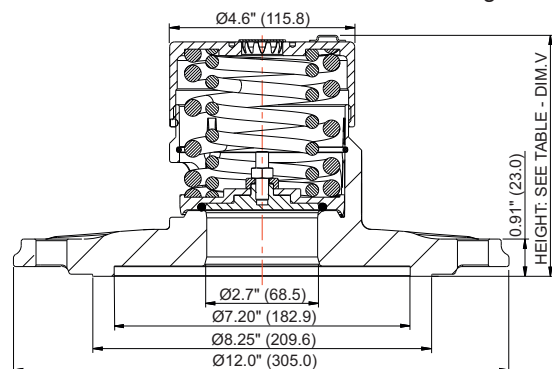



## 2 1/2" Flanged Super Maxi Relief Valve: AAR

Part No: 0R3/XXXX006X

### Parts Drawing

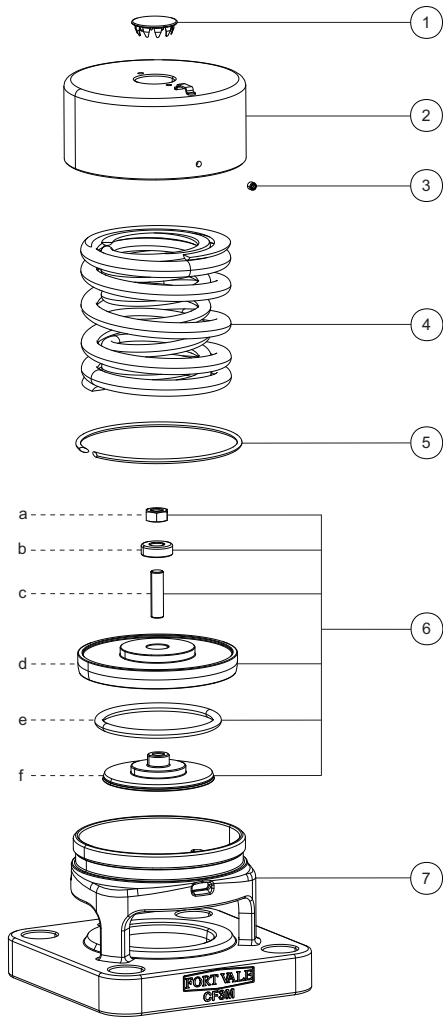

### Parts List

Item	Description	Part No.
1	Stainless steel plug	10978/1
2	Top cap: 75 PSI set pressure Top cap: 165 PSI set pressure	1760/0028 1860/0041/5
3	Setscrew	5121-001
4	Spring pair: 75 PSI Spring pair: 165 PSI	6104-0570 6104-1264R
5	Retaining ring clip	5120-067
6	Composite pressure plate assy:	1860/X190XXX
a	5/16" full nut	5112-019
b	Retaining washer	1860/0190/3
c	5/16" stud	312/1018
d	Outer pressure plate <b>*Note</b>	1860/019AXXX
e	Pressure O ring <b>*Note</b>	ORB335XX
f	Inner pressure plate <b>*Note</b>	1860/0190/2X
7	Body: 6" tongue & groove (T) Body: 6" raised face (R) Body: 12" tongue & groove (S) Body: 12" raised face (V)	1860/0626 1860/0625 1860/0627 1860/0628

**NOTE:** The valve specification changes the Part No.





# Part Number Breakdown - 0R3/XXXX006X

## Data Sheet

### Flanged High-Pressure Super Maxi Relief Valve: AAR Specification

Example:

**0R3/ 0 075 00 6 T**

**Valve Type** \_\_\_\_\_

- 0R3/** Stainless steel body & springs
- 0U3/** PFA coated wetted areas & Halar coated springs
- HR3/** Metal parts SB574 UNS10276 & Inconel springs

**Seal Type** \_\_\_\_\_

All materials are proprietary brand, where applicable

- 0** Viton A ®
- 1** Fortyt (FEP outer/silicone core)
- 3** Kalrez 6375 ®
- 4** HNBR
- 7** Perfluoroelastomer
- 9** EPDM
- A** Aflas ®
- B** Viton B ® (Dupont)
- C** Chemraz 505 ®
- D** White EPDM (Food grade)
- E** Viton GF-S ® (Trelleborg CS5350)
- F** Black Neoprene
- G** Viton GFLT ®
- H** Black EPDM (Trelleborg EP787)
- J** Fortyt (FEP outer/Viton core)
- K** Kalrez 1050LF ®
- N** White Neoprene (Food grade)
- P** PFA lined pressure plate
- S** Viton GF-S ® (Peroxide cured)
- T** Hi-temp. Fortyt (PFA outer/silicone core)
- U** Viton B ® (Trelleborg 4273B)
- W** White Buna N (Food grade)

**Pressure Setting (PSIG)** \_\_\_\_\_

- 075** 75 PSIG
- 165** 165 PSIG

**Vacuum Setting** \_\_\_\_\_

- 00** No vacuum

**Bore Diameter** \_\_\_\_\_

- 6** 2.70" (68.1mm)

**Flange Specification** \_\_\_\_\_

- A** 8 holes on a 10.3" PCD - Raised face PFA coated - AAR Fig.E21 (A)
- J** 3 holes on a 5.50" PCD - Raised face PFA coated
- R** 4 holes on a 6.25" PCD - Raised face
- S** 8 holes on a 10.3" PCD - Tongue & groove
- T** 4 holes on a 6.25" PCD - Tongue & groove
- V** 8 holes on a 10.3" PCD - Raised face - AAR Fig. E21 (A)





Our subsidiaries are located in:

**US Office**

126 N. Virginia  
La Porte  
TX 77571  
USA

Tel: +1 281 471 8100

Fax: +1 281 471 8116

Email: [ussales@fortvale.com](mailto:ussales@fortvale.com)

**Head Office**

Calder Vale Park  
Simonstone Lane  
Simonstone, Burnley  
Lancashire, BB12 7ND, UK

Tel: +44 (0) 1282 687120

Fax: +44 (0) 1282 687110

Email: [sales@fortvale.com](mailto:sales@fortvale.com)

**China Office**

Fort Vale Engineering Shanghai Ltd  
Building 11 88 Yuanshan Road  
Xinzhuang Industry Park  
Shanghai 201108 China

Tel: +86 21 6442 1367

Fax: +86 21 6442 1376

Email: [cnsales@fortvale.com](mailto:cnsales@fortvale.com)

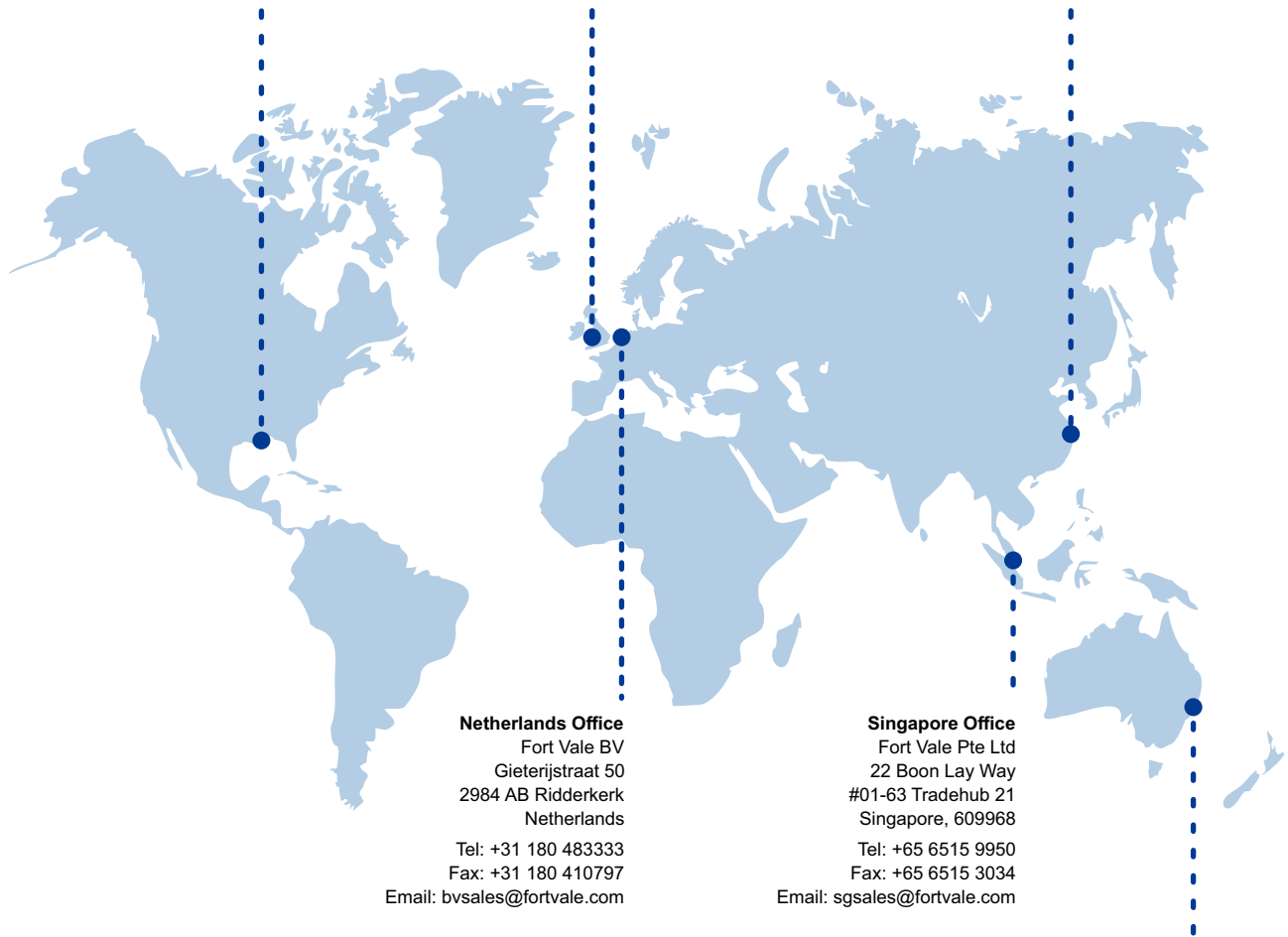

**Netherlands Office**

Fort Vale BV  
Gieterijstraat 50  
2984 AB Ridderkerk  
Netherlands

Tel: +31 180 483333

Fax: +31 180 410797

Email: [bvsales@fortvale.com](mailto:bvsales@fortvale.com)

**Singapore Office**

Fort Vale Pte Ltd  
22 Boon Lay Way  
#01-63 Tradehub 21  
Singapore, 609968

Tel: +65 6515 9950

Fax: +65 6515 3034

Email: [sgsales@fortvale.com](mailto:sgsales@fortvale.com)

**Australia Office**

Fort Vale Australia Pty Ltd  
Bellwood Business Park  
Unit 14, 49 Bellwood Street  
Darra, Queensland, 4076

Tel: +61 7 3189 5059

Email: [ausales@fortvale.com](mailto:ausales@fortvale.com)

We also have Authorised Distributors around the world to provide you with product sales and after-market services. To find your nearest distributor, please visit our website - [www.fortvale.com](http://www.fortvale.com)

