



WARNING: Installation, dis-assembly, repair and main-tenance **MUST** be performed only by qualified personnel. All

gas **MUST** be evacuated from the system before starting repairs.

Installation, usage and maintenance of this product must be in compliance with all RegO® instructions as well as requirements and provisions of NFPA #54, NFPA #58, DOT, ANSI, all applicable federal, state, provincial and local standards, codes, regulations and laws.

Inspection and maintenance on a periodic basis is essential.

Be sure all instructions are read and understood before instal-lation, operation and maintenance. These instructions must be passed along to the end user of the product.

RegO Rail Tank Car equipment is AAR approved. If repaired, the continued validity of the AAR approval is contingent upon proper inspection to determine what needs to be repaired; proper repair using RegO OEM parts and procedures, proper testing for leakage and performance following repairs and installation.

ECI EXPRESSLY DISCLAIMS ANY AND ALL LIABILITY – UNDER ANY THEORY, WHETHER CONTRACT, WARRANTY, TORT OR OTHERWISE – RELATING IN ANY MANNER TO ANY RAIL TANK CAR EQUIPMENT REPAIRED USING ANY PRODUCTS NOT MANU-FACTURED BY ECI.

USE OF ANY PRODUCTS NOT MANUFACTURED BY ECI TO RE-PAIR ANY RAIL TANK CAR EQUIPMENT WILL INVALIDATE ANY AND ALL WARRANTIES OF THE RAIL TANK CAR EQUIPMENT, WHETHER EXPRESS OR IMPLIED.

CAUTION: Contact or inhalation of liquid propane, ammonia and their vapors can cause serious injury or death! NH₃ and LP-Gas must be released outdoors in air currents that will insure disper-sion to prevent exposure to people and livestock. LP-Gas must be kept far enough from any open flame or other source of ignition to prevent fire or explosion! LP-Gas is heavier than air and may not disperse or evaporate rapidly if released in still air.

TA7894-50 and TA7894P-51 Rebuild Kits For TA7894P Tank Car Valves



A. Disassembly

CAUTION: EVACUATE ALL GAS FROM THE SYSTEM BEFORE ANY DISASSEMBLY OR REPAIR.

1. Remove 2" plug from valve outlet.
2. Turn handwheel counterclockwise as far as it will go to release any gas remaining in the container.

CAUTION: Do not apply force after valve is fully open.

3. Remove flange by removing the 9/16" (8) flange cap screws. Set all aside.
4. Remove and discard the flange gasket.
5. Using a 13/16" wrench, remove four cap screws from bonnet and set aside for reassembly. Carefully remove bonnet assembly from valve body. Set bonnet assembly aside.
6. Remove body gasket and discard.
7. Clamp the square section of bonnet in a vise.
8. Remove handwheel locknut with a small wrench to allow removal of washer, information disc and handwheel. Set items aside.
9. Using a 1-3/8" wrench with a handle of sufficient length to develop a minimum of 1000 in-lbs (83 ft-lbs) torque, carefully remove seal housing from bonnet.

Figure 1-TA7894P

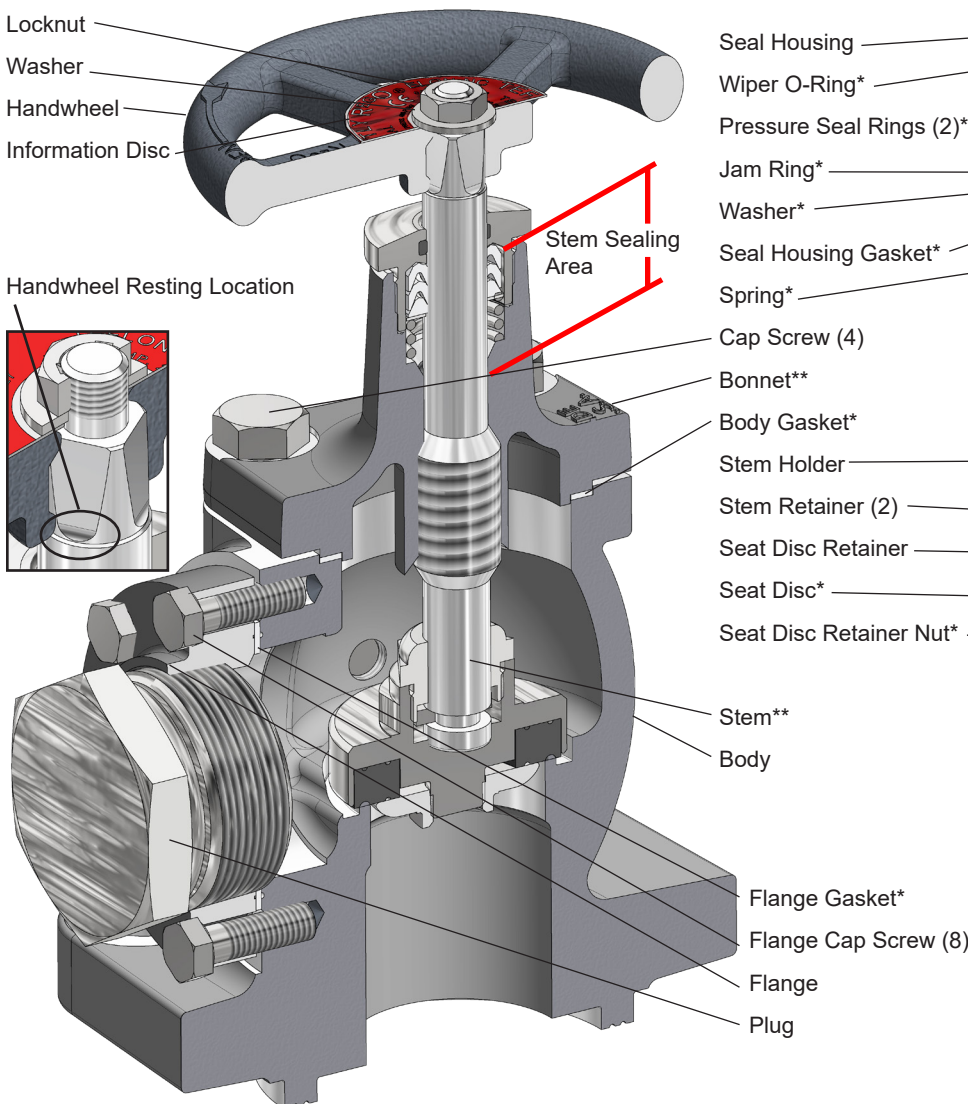

CAUTION: Do not mar finish of stem.

10. Remove and discard (2) pressure seal rings, jam ring and wiper o-ring from seal housing.
11. Using a small wrench on the square section of the stem, unscrew stem down and out through the bottom of bonnet by turning clockwise (as viewed from top).

CAUTION: Stem inspection required.

12. Inspect the stem closely for definite signs of wear, nicks or scratches, in the Stem Sealing Area, see Figure 1. If any mechanical cleaning is needed, use emery cloth or paper (500-1000 grit) and polish stem sealing area using a circular motion.

CAUTION: Raised or sharp edges on the stem can damage and expand the packing seals when pressing onto the stem.

13. Continue to inspect the handwheel resting location where the stem changes from square to round, see Figure 1 Handwheel Resting Location. Remove any raised edges or burrs using a fine file and emery cloth that are higher than the stem diameter. Using an old seal, press seal on and off this area to determine if any resistance is felt. Resistance may require additional clean up. If stem is found to be in good condition, continue section B-1 of the rebuild instructions.

Figure 2-Seal Housing Assembly

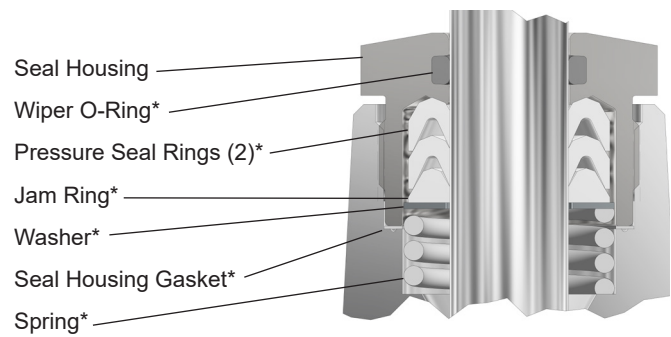

Figure 3-Seat Disc and Retainer Assembly

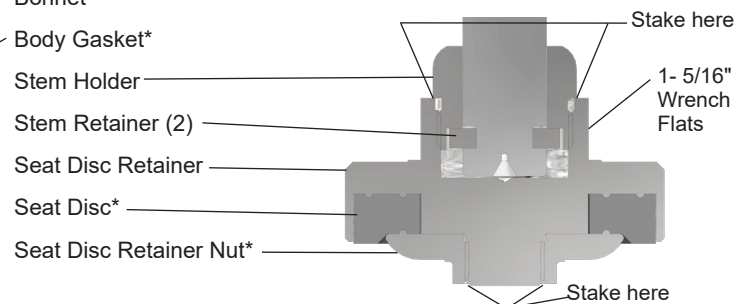
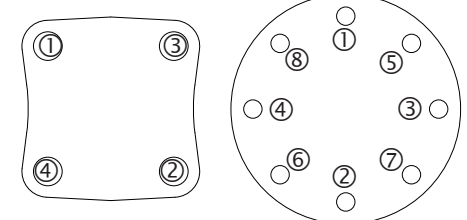

Figure 4-Screw Tightening Sequence Bonnet Flange Outlet Flange



Apply minimum 540±25 in-lbs (45±2 ft-lbs) torque using a tightening sequence of alternating bolts in a crisscross pattern.

Apply minimum 300±25 in-lbs (25±2 ft-lbs) torque using a tightening sequence of alternating bolts in a crisscross pattern.

* All components included in the TA7894-50 kit are recommended for valve rebuild.

** Must be ordered separately from RegO®.

NOTE: If any permanent damage is found discard the stem and seal housing. Use TA7894P-51 Stem Kit and follow the alternate steps outlined in section B-2 Titled Angle Valve Reassembly Instructions with the TA7894P-51 Stem Kit.

*NOTE: Inspect stem** threads and mating threads in bonnet**. If any threads show definite wear, discard part, and install a new one.*

14. Remove seat disc retainer nut by using 1-5/16" wrench to secure retainer and another wrench to remove nut.
15. Remove and discard seat disc.

B-1 Angle Valve Reassembly See Figures 1,2 & 3

1. Apply non-detergent grease liberally to the threads of the stem.
2. Screw the stem clockwise (as viewed from seat disc) into the bottom of the bonnet with great care to avoid damaging the stem finish.
3. Install new seat disc into seat disc retainer by pressing into the recess of seat disc retainer as shown in Figure 3.
4. Apply Loctite 271® thread locking compound to the first three threads of seat disc retainer.

CAUTION: Do not allow Loctite to contact seat disc.

5. Thread on disc retaining nut and tighten with a wrench to 240-270 in-lbs (20-22.5 ft-lbs) torque. Stake nut in two places at retainer threads to prevent loosening. See Figure 3. Set assembly aside.
6. Install new seal housing gasket, new spring, new washer and jam ring over stem and into bonnet.
7. Install new wiper o-ring in groove of seal housing.
8. Apply a thin film of non-detergent grease to the pressure seal rings and carefully insert one at a time into the full depth of the seal housing.
9. Apply 1/8" stripe Loctite 271® thread locking compound across threads in three places equally spaced around seal housing.
10. Place seal housing carefully over the stem to avoid damaging the edges of seal rings and thread into bonnet. Tighten to 800 in-lbs (67 ft-lbs) torque, using a 1-3/8" wrench with a handle of appropriate length.
11. Apply non-detergent grease to each side of new body gasket and install into body.

CAUTION: Using the handwheel, verify the stem is in the full open (valve back seated) position to prevent seat disc from being forced against seat when bonnet is assembled to valve body.

12. Place bonnet over body and align holes for cap screws.
13. Install (4) cap screws, hand tight.
14. Using 13/16" wrench, tighten bonnet cap screws to 540 in-lbs (45 ft-lbs) torque using a crisscross tightening sequence. See Figure 4.
15. Place handwheel and information disc on stem, secure with washer and locknut and tighten firmly with a small wrench.
16. Apply non-detergent grease to each side of flange gasket then install in body.
17. Reinstall flange to outlet and hand tighten (8) flange cap screws.
18. Torque each flange cap screw using 9/16" wrench to 300 in-lbs (25 ft-lbs) minimum using a crisscross tightening sequence. See Figure 4.
19. Turn handwheel to closed position for Bench Test.

B-2 Angle Valve Reassembly With TA7894P-51 Stem Kit See Figures 1,2 & 3

NOTE: If replacing stem, follow disassembly steps 1A - 1D found below then continue with reassembly.

- 1A. Using 1-1/8" wrench on the stem holder (left hand threads) and a 1-5/16" wrench on seat disc retainer (left hand threads) turn clockwise (left hand threads) (as shown in Figure 1) to loosen the stem holder from the seat disc retainer.
- 1B. Remove and retain the two stem retainers (crescent shaped) once the stem holder and seat disc retainer are separated.
- 1C. Remove the stem holder from the old stem and set the stem holder aside.
- 1D. Discard the old stem and old seal housing.
2. Apply non-detergent grease liberally to the threads of the new stem.
3. Screw the new stem clockwise (as viewed from seat disc) into the bottom of the bonnet with great care to avoid damaging the stem finish.
4. Install the new seal housing gasket, new spring, new seal housing washer and jam ring over the stem and into the bonnet.
5. Install the new wiper o-ring in the groove of the new seal housing.
6. Apply a thin film of non-detergent grease to the pressure seal rings and carefully insert one at a time into the full depth of the new seal housing.
7. Apply 1/8" stripe of Loctite 271® thread locking compound across the threads in three places equally spaced around the new seal housing.
8. Place the new seal housing carefully over the stem to avoid damaging the edges of the seal rings and thread into the bonnet clockwise. Tighten to 800±25 in-lbs (67±2 ft-lbs) torque, using a 1-3/8" wrench with a handle of appropriate length.
9. Place the handwheel and information disc on the stem, secure with the washer and locknut and tighten firmly with a 9/16" wrench.
10. Install the stem holder on the new stem.
11. Install the two (crescent shaped) stem retainers on the main stem.
12. Apply Loctite 271® thread locking compound to the stem holder external threads and tighten into the seat disc retainer. Using 1-1/8" wrench on the stem holder and 1-5/16" wrench on the seat disc retainer, torque the connection to insure metal to metal contact between the two. Stake as shown in Figure 3 (two places).
13. Install new seat disc by pressing it into the seat disc retainer.
14. Apply Loctite 271® thread locking compound to the first three threads of the seat disc retainer.

CAUTION: Do not allow Loctite to contact the seat disc.

15. Thread on the seat disc retaining nut and tighten with a wrench to 240-270 in-lbs (20-22.5 ft-lbs) torque. Stake the nut in two places at the retainer threads (See Figure 3) to prevent loosening.
16. Apply non-detergent grease to each side of new body gasket and install into body.

CAUTION: Using the handwheel, verify the stem is in the full open (valve back seated) position to prevent seat disc from being forced against seat when bonnet is assembled to valve body.

17. Place bonnet over body and align holes for cap screws.
18. Install (4) cap screws, hand tight.
19. Using 13/16" wrench, tighten bonnet cap screws to 540 in-lbs (45 ft-lbs) torque using a crisscross tightening sequence. See Figure 4.

20. Apply non-detergent grease to each side of flange gasket then install in body.
21. Reinstall flange to outlet and hand tighten (8) flange cap screws.
22. Torque each flange cap screw with a 9/16" wrench to 300 in-lbs (25 ft-lbs) minimum using a crisscross tightening sequence. See Figure 4.
23. Turn handwheel to closed position for Bench Test.

Bench Test

1. Torque handwheel to 400 in-lbs (33 ft-lbs). Verify outlet is open.
2. Pressurize valve to 300-500 psi (through the inlet connection) and check valve for leakage, when looking into the outlet port, by applying a high quality leak detection solution around seat area and seat cavity. Observe for one minute to detect leaks.

3. Release 300-500 psi, apply 15-20 psi and look for any leakage as above.
4. Install outlet plug, again apply 300-500 psi and slowly open valve by turning handwheel 1/4 turn incrementally. Check valve for leakage by applying a high quality leak detection solution around stem, seal housing and bonnet joint. Continue to rotate handwheel 1/4 turn incrementally until valve is fully open (not back seated). Observe for one minute to detect leaks.

CAUTION: Wrenches must never be used to operate valves equipped with handwheels designed for hand operation.

NOTICE

LP-Gas is extremely flammable and explosive. Failure to install parts exactly as described in the instructions could result in a product that will not perform satisfactorily. Even if parts are correctly installed, the product might fail to perform satisfactorily, if other parts are worn, corroded or dirty. Improper repair can cause leaks and malfunction, which could result in bodily injury and property damage. Any such use or installation of parts must ONLY be done by experienced and trained personnel using accepted governmental and industrial safety procedures.

Most RegO® products are listed with Underwriters Laboratories as manufactured. If repaired, the continued validity of the UL listing is contingent upon proper inspection to determine what needs repairing, proper repair using RegO® parts and procedures, and proper testing for leakage and performance following repairs and installation.

RegO® assumes no responsibility or liability for performance of products repaired in the field. It must be clearly understood that the person or organization repairing the product assumes total responsibility for performance of the product.

LIMITED 10 YEAR WARRANTY

RegO® warrants to the original purchasers the products and repair kits manufactured by it to be free from defects in materials and workmanship under normal use and service for a period of 10 years from the date of manufacture. If within thirty days after buyer's discovery of what buyer believes is a defect, buyer notifies in writing and ships (at buyer's expense) the product to RegO® at 100 RegO Drive, Elon, N.C. 27244, RegO®, at its option, and within forty-five days of receipt, will repair, replace F.O.B. point of manufacture, or refund the purchase price of that part or product found by RegO® to be defective. Failure of buyer to give such written notice and ship the product within thirty days shall be deemed an absolute and unconditional waiver of any and all claims of buyer arising out of such defect.

This warranty does not extend to any product or part that is not installed and used continuously after installation in accordance with RegO®'s printed instructions, all applicable state and local regulations, and all applicable national standards, such as those promulgated by NFPA, DOT and ANSI. This warranty does not extend to any product or part that has been damaged by accident, misuse, abuse, failure to maintain, or neglect, nor does it extend to any product or part which has been modified, altered, disassembled, or repaired in the field. This warranty does not cover any cosmetic issues, such as scratches, dents, marring, fading of colors or discoloration.

EXCEPT AS EXPRESSLY SET FORTH ABOVE, AND SUBJECT TO THE LIMITATION OF LIABILITY BELOW, REGO® MAKES NO OTHER WARRANTY, AND EXPRESSLY DISCLAIMS, ANY EXPRESS OR IMPLIED WARRANTIES, INCLUDING, BUT NOT LIMITED TO, THE IMPLIED WARRANTIES OF MERCHANTABILITY AND FITNESS FOR A PARTICULAR PURPOSE, WITH RESPECT TO ITS PRODUCTS AND PARTS, WHETHER USED ALONE OR IN COMBINATION WITH OTHERS. REGO® DISCLAIMS ALL WARRANTIES NOT STATED HEREIN.

This Limited Warranty is given by Engineered Controls International LLC, of 100 RegO Drive Elon, NC 27244 USA, (336) 449-7707.

LIMITATION OF LIABILITY

RegO® total liability for any and all losses and damages arising out of any cause whatsoever shall in no event exceed the purchase price of the products or parts in respect of which such cause arises, whether such causes be based on theories of contract, negligence, strict liability, tort or otherwise.

RegO® shall not be liable for incidental, consequential or punitive damages or other losses. RegO® shall not be liable for, and buyer assumes any liability for all personal injury and property damage connected with the handling, transportation, possession, further manufacture, other use or resale of products, whether used alone or in combination

with any other products or materials.

From time to time buyers might call to ask RegO® for technical advice based upon limited facts disclosed to RegO®. If RegO® furnishes technical advice to buyer, whether or not a buyer's request, with respect to application, further manufacture or other use of the products and parts, RegO® shall not be liable for such technical advice or any such advice provided to buyer by any third party and buyer assumes all risks of such advice and the results thereof.

NOTE: Some states do not allow the exclusion or limitation of incidental, consequential or punitive damages, so the above limitation or exclusion may not apply to you. The warranty gives you specific legal rights, and you may have other rights that vary from state to state. The portions of the limited warranty and limitation of liability shall be considered severable and all portions which are not disallowed by applicable law shall remain in full force and effect.

The benefits given by the Limited Warranty above are in addition to any other rights and remedies to which you may be entitled by law.

NOTE TO AUSTRALIAN PURCHASERS: The following applies if you purchased this product as a "consumer" as defined in the Australian Consumer Law. Our goods come with guarantees that cannot be excluded under the Australian Consumer Law. You are entitled to a replacement or refund for a major failure and compensation for any other reasonably foreseeable loss or damage. You are also entitled to have the goods repaired or replaced if the goods fail to be of acceptable quality and the failure does not amount to a major failure. Information regarding how to return a product and make a claim under this Limited Warranty is set forth below.

Nothing in this document purports to modify or exclude your rights if any under the Australian Consumer Law, or other laws which cannot be lawfully be modified or excluded.

WARNING

All RegO® products are mechanical devices that will eventually become inoperative due to wear, corrosion and aging of components made of materials such as rubber, etc. The environment and conditions of use will determine the safe service life of these products. Periodic inspection and maintenance are essential to avoid serious injury and property damage.

Many RegO® products are manufactured components which are incorporated by others on or in other products or systems used for storage, transport, transfer and otherwise for use of toxic, flammable and dangerous liquids and gases. Such substances must be handled by experienced and trained personnel only, using accepted governmental and industrial safety procedures.

NOTICE TO USERS OF PRODUCTS

The Limited Warranty stated above is a factory warranty to the first purchasers of RegO® products. Since most users have purchased these products from RegO® distributors, to make a claim under this Limited Warranty the user must within thirty (30) days after the user's discovery of what user believes is a defect, notify in writing and return the product (at the user's expense) to the distributor from whom he purchased the product/part. The distributor may or may not at the distributor's option choose to submit the product/parts to RegO®, pursuant to this Limited Warranty. Failure by buyer to give such written notice and return the product within thirty (30) days shall be deemed an absolute and unconditional waiver of buyer's claim for such defects. Acceptance of any alleged defective product/parts by RegO®'s distributor for replacement or repairs under the terms of RegO®'s Limited Warranty in no way determines RegO®'s obligations under this Limited Warranty.

Because of a policy of continuous product improvement, RegO® reserves the right to change designs, materials or specifications without notice.



Elon, N.C. 27244 U.S.A. Phone +1 (336) 449-7707 Fax (336) 449-6594 www.regoproducts.com

Printed in USA REV S 16-0923-0281
Instruction Sheet TA7894-300

RegO® is a registered trademark of Engineered Controls International, LLC.